



Ether**CAT**[®]

The Ethernet Fieldbus.

EtherCAT is:

- Faster
- Synchronization
- Industrial Ethernet
- Flexible
- Easier to configure
- Cost effective
- Easier to implement
- Well proven
- Open
- Conformance
- Safety
- Redundancy
- Versatile

- Ethernet...
 - is state-of-the-art technology at controller level
 - are standard components, driven by the office sector
- Fieldbus...
 - is lower costs
 - is performance
 - is deterministic (real time) distributed control
- Advantages of the combination:
 - Lower costs because the use of standard components
 - Access to internet technology (e.g. webserver)
 - Reduction of interfaces
 - Real time communication with cycle times $<100 \mu\text{s}$
 - Flexible topology, arbitrarily extendable

EtherCAT is:

- Faster
- Synchronization
- Industrial Ethernet
- Flexible
- Easier to configure
- Cost effective
- Easier to implement
- Well proven
- Open
- Conformance
- Safety
- Redundancy
- Versatile

- EtherCAT is real time down to the I/O level
- No underlying sub-systems any more
- No delays in gateways
- In- and outputs, sensors, actuators, drives, displays:
everything in one system!

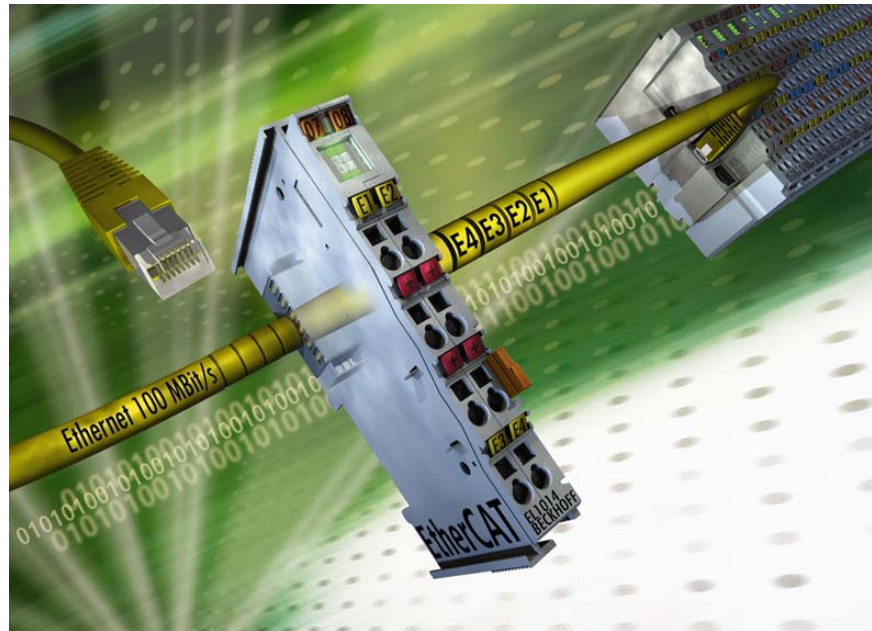

EtherCAT is:

- Faster
- Synchronization
- Industrial Ethernet
- Flexible
- Easier to configure
- Cost effective
- Easier to implement
- Well proven
- Open
- Conformance
- Safety
- Redundancy
- Versatile

- Transmission Rate:
 - 2 x 100 Mbit/s (Fast Ethernet, Full-Duplex)
- Update Times:
 - 256 digital I/O in 11 μ s
 - **1000 digital I/O distributed to 100 nodes in 30 μ s = 0.03 ms**
 - 200 analog I/O (16 bit) in 50 μ s, 20 kHz Sampling Rate
 - **100 Servo-Axis (each 8 Byte In + Out) in 100 μ s = 0.1 ms**
 - 12000 digital I/O in 350 μ s

EtherCAT is faster

EtherCAT is:

- Faster
- Synchronization
- Industrial Ethernet
- Flexible
- Easier to configure
- Cost effective
- Easier to implement
- Well proven
- Open
- Conformance
- Safety
- Redundancy
- Versatile

- Bandwidth Usage of Ethernet for I/O and Drives:
 - Ethernet Frame: ≥ 84 Bytes
incl. Preamble + IPG (interpacket gap)

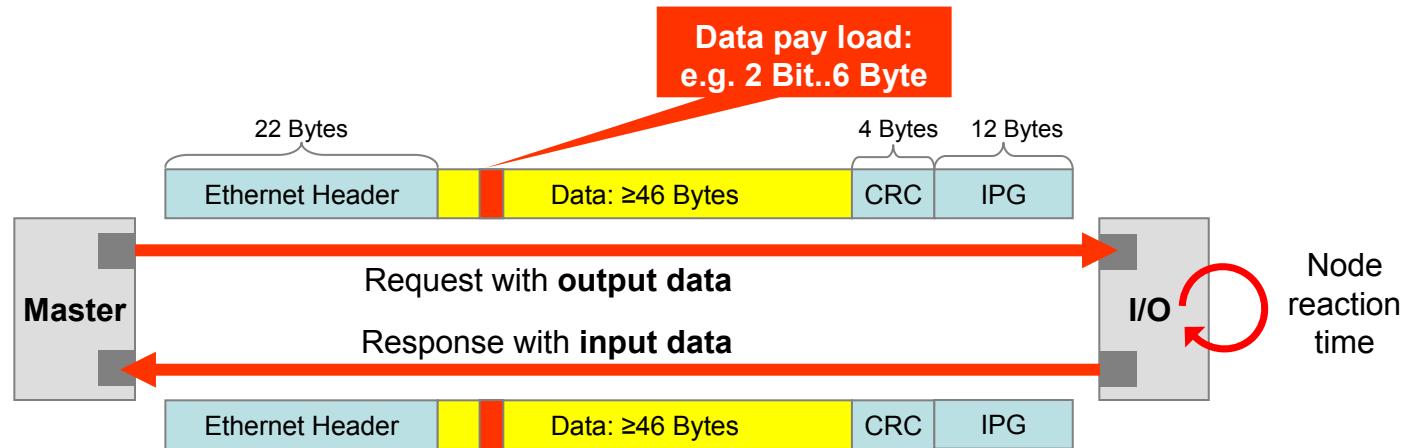

- with 4 Byte input + 4 Byte output per node:
 - **4,75%** application data ratio at **0 μ s** reaction time/node
 - **1,9%** application data ratio at **10 μ s** reaction time/node

EtherCAT is:

- Faster
- Synchronization
- Industrial Ethernet
- Flexible
- Easier to configure
- Cost effective
- Easier to implement
- Well proven
- Open
- Conformance
- Safety
- Redundancy
- Versatile

- Bandwidth Usage Comparison:
 - At 4 Byte user data per node:
 - Polling / Timeslicing: ~ 2..5 %
 - From 2 Bit user data per node:
 - **EtherCAT: ~ 80..97 % (Full Duplex, 2 x 100 MBit/s)**

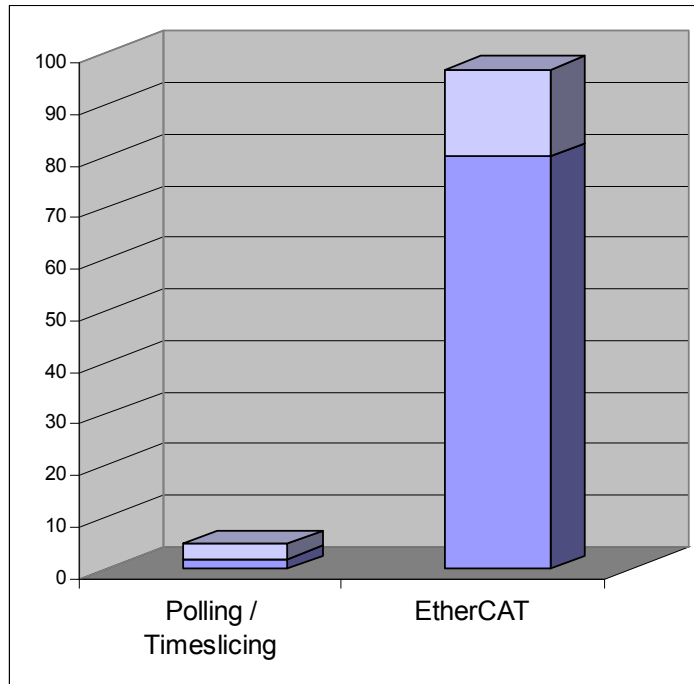

EtherCAT is:

- Faster
- Synchronization
- Industrial Ethernet
- Flexible
- Easier to configure
- Cost effective
- Easier to implement
- Well proven
- Open
- Conformance
- Safety
- Redundancy
- Versatile

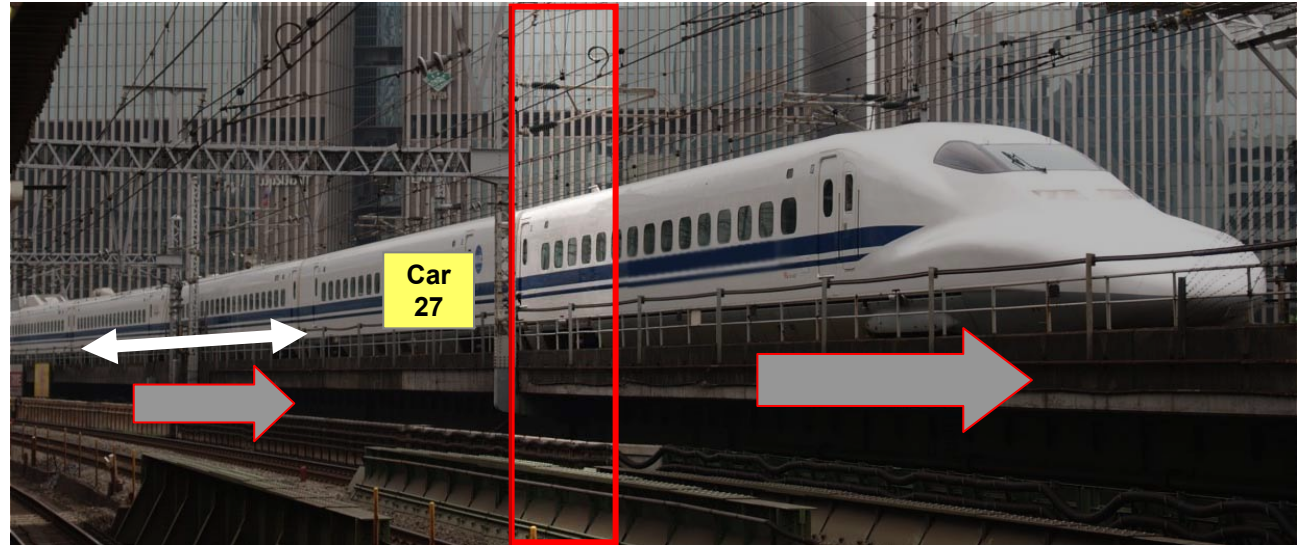

- Analogy Fast Train:
 - “Train” (Ethernet Frame) does not stop
 - Even when watching “Train” through narrow window one sees the entire “Train”
 - “Car” (Sub-Telegram) has variable length
 - One can “extract” or “insert” single “persons” (Bits) or entire “groups” (Bytes) – even multiple groups per train

Functional Principle: Ethernet „on the fly“

EtherCAT is:

- Faster
- Synchronization
- Industrial Ethernet
- Flexible
- Easier to configure
- Cost effective
- Easier to implement
- Well proven
- Open
- Conformance
- Safety
- Redundancy
- Versatile

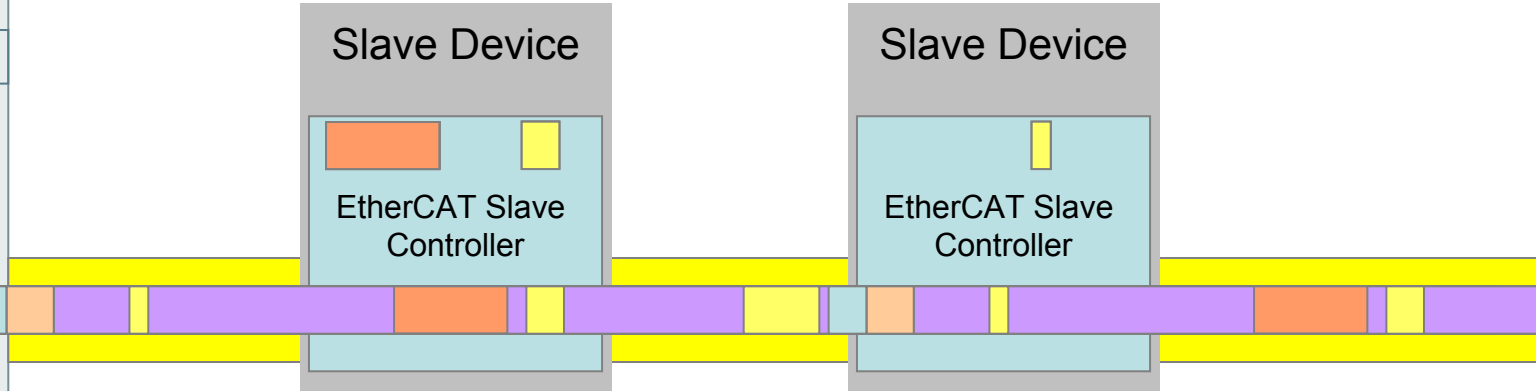

- Process data is extracted and inserted on the fly:
 - Process data size per slave almost unlimited (1 Bit...60 Kbyte, if needed using several frames)
 - Compilation of process data can change in each cycle, e.g. ultra short cycle time for axis, and longer cycles for I/O update possible
 - in addition asynchronous, event triggered communication

EtherCAT is:

- Faster
- Synchronization
- Industrial Ethernet
- Flexible
- Easier to configure
- Cost effective
- Easier to implement
- Well proven
- Open
- Conformance
- Safety
- Redundancy
- Versatile

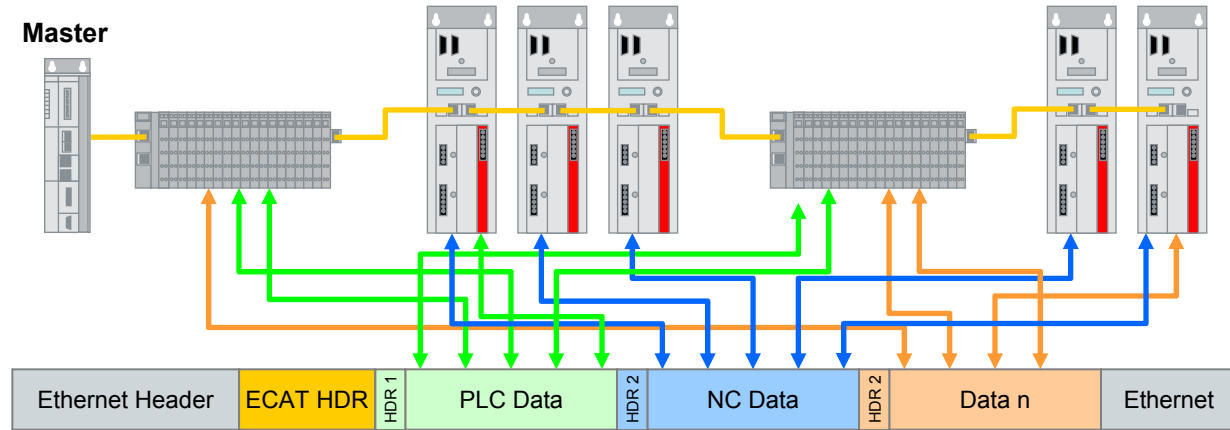

- Minimal protocol overhead via implicit addressing
 - Optimized telegram structure for decentralized I/O
 - Communication completely in hardware: maximum (+ predictable!) performance
 - No switches needed if only EtherCAT devices in the network
 - Outstanding diagnostic features
 - Ethernet-compatibility maintained

Performance: Application Example

EtherCAT is:

- Faster
- Synchronization
- Industrial Ethernet
- Flexible
- Easier to configure
- Cost effective
- Easier to implement
- Well proven
- Open
- Conformance
- Safety
- Redundancy
- Versatile

- 40 Axis (each 20 Byte Input- and Output-Data)
- 50 I/O Station with a total of 560 EtherCAT Bus Terminals
- 2000 Digital + 200 Analog I/O, Bus Length 500 m
- **Performance EtherCAT: Cycle Time = 276 μ s at 44 % Bus Load, Telegram Length = 122 μ s**

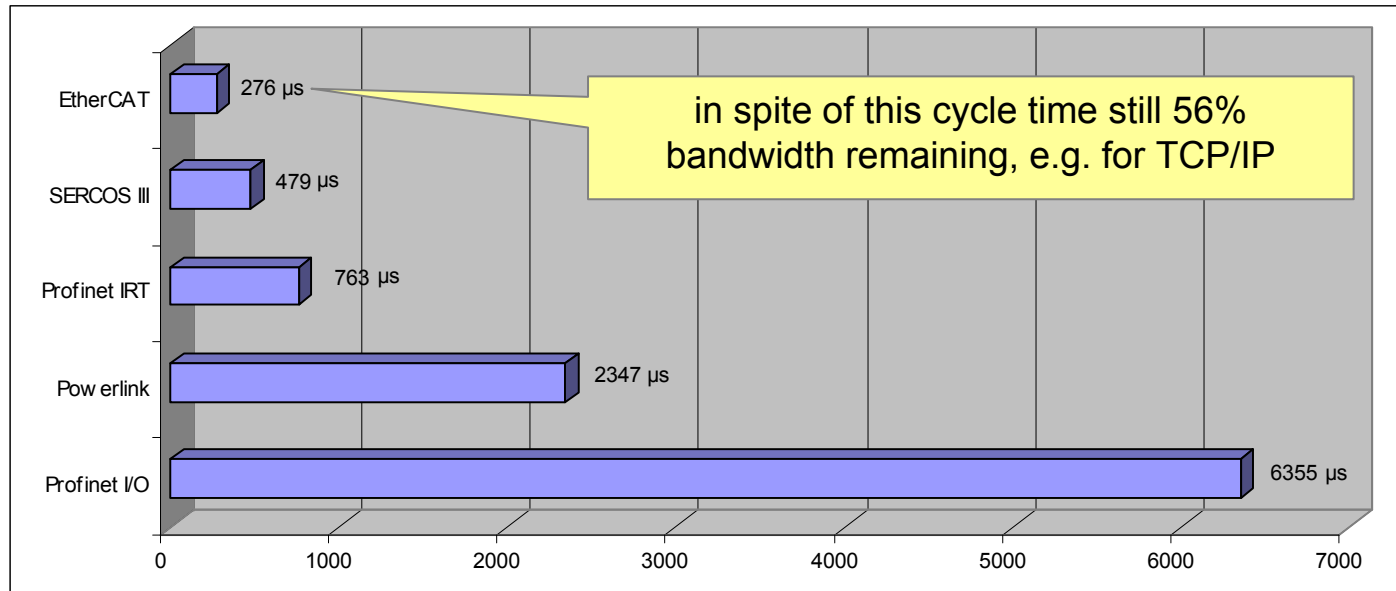

'Slow' Control Systems benefit, too

EtherCAT is:

- Faster
- Synchronization
- Industrial Ethernet
- Flexible
- Easier to configure
- Cost effective
- Easier to implement
- Well proven
- Open
- Conformance
- Safety
- Redundancy
- Versatile

- Reaction time with legacy fieldbus I/O:

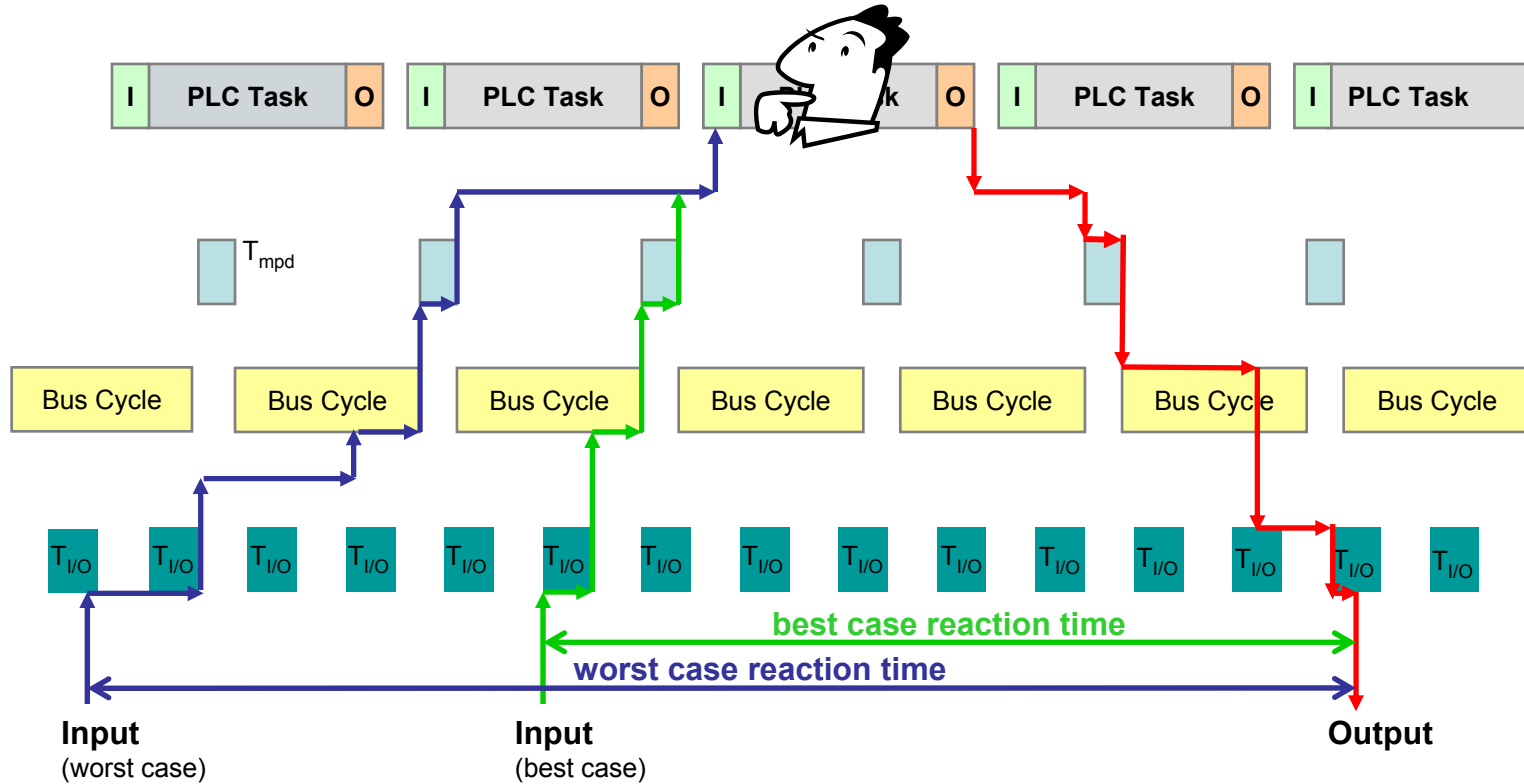

T_{mpd} : Master Processing Delay
 $T_{I/O}$: Local I/O Update Time
 (local Extension Bus + Firmware)

'Slow' Control Systems benefit, too

EtherCAT is:

- Faster
- Synchronization
- Industrial Ethernet
- Flexible
- Easier to configure
- Cost effective
- Easier to implement
- Well proven
- Open
- Conformance
- Safety
- Redundancy
- Versatile

• System Architecture with EtherCAT:

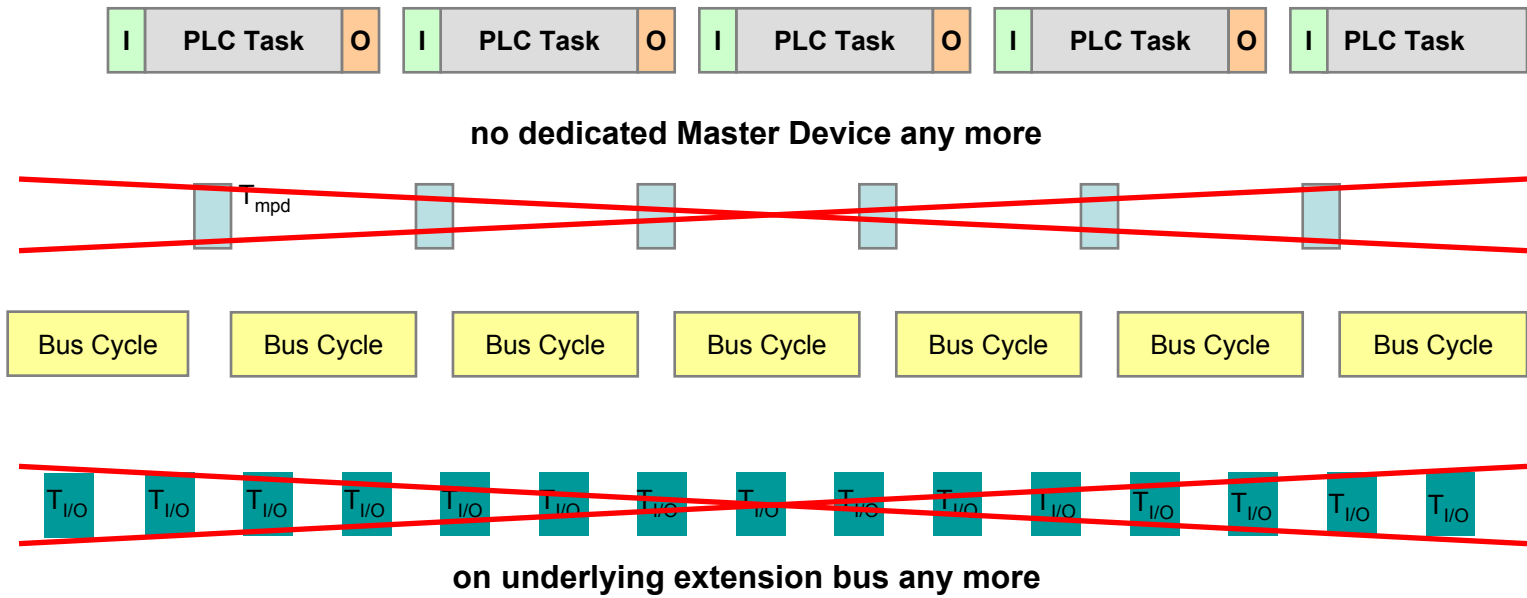

'Slow' Control Systems benefit, too

EtherCAT is:

- Faster
- Synchronization
- Industrial Ethernet
- Flexible
- Easier to configure
- Cost effective
- Easier to implement
- Well proven
- Open
- Conformance
- Safety
- Redundancy
- Versatile

- System Architecture with EtherCAT:

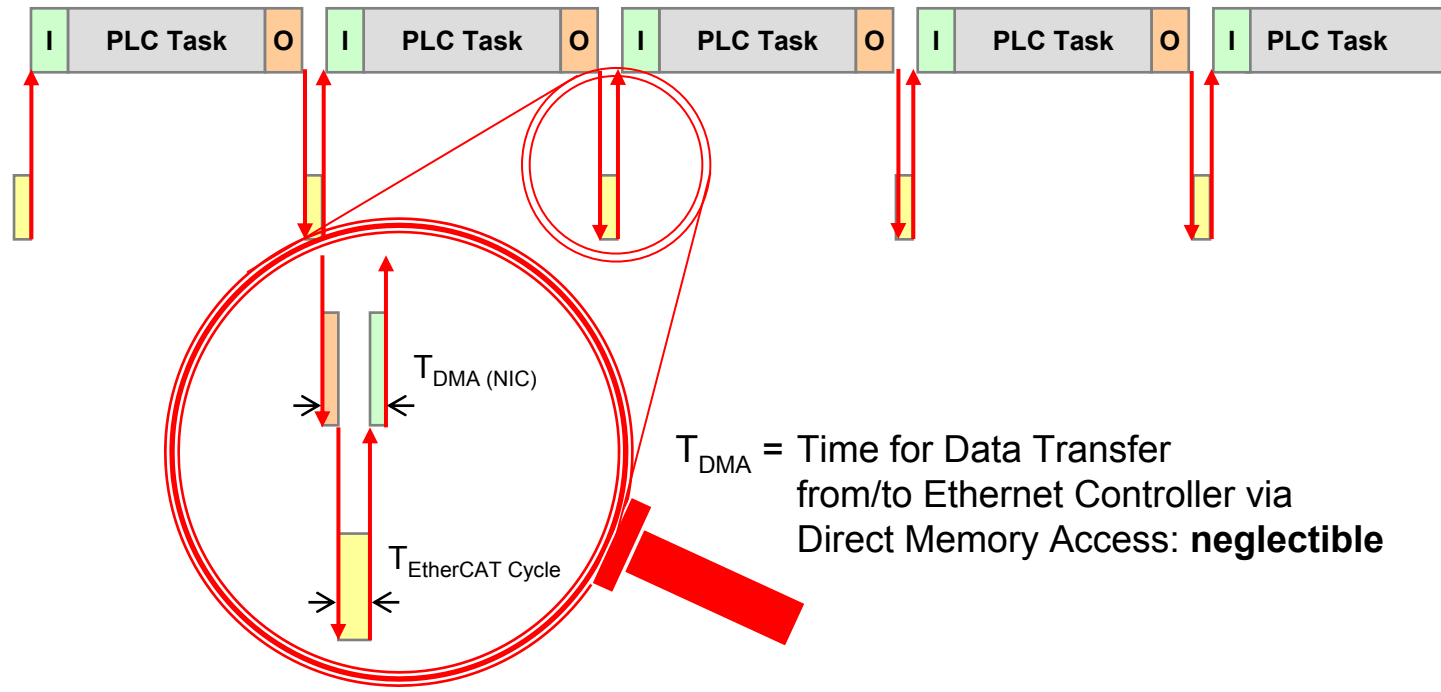

'Slow' Control Systems benefit, too

EtherCAT is:

- Faster
- Synchronization
- Industrial Ethernet
- Flexible
- Easier to configure
- Cost effective
- Easier to implement
- Well proven
- Open
- Conformance
- Safety
- Redundancy
- Versatile

- Reaction Time with EtherCAT:

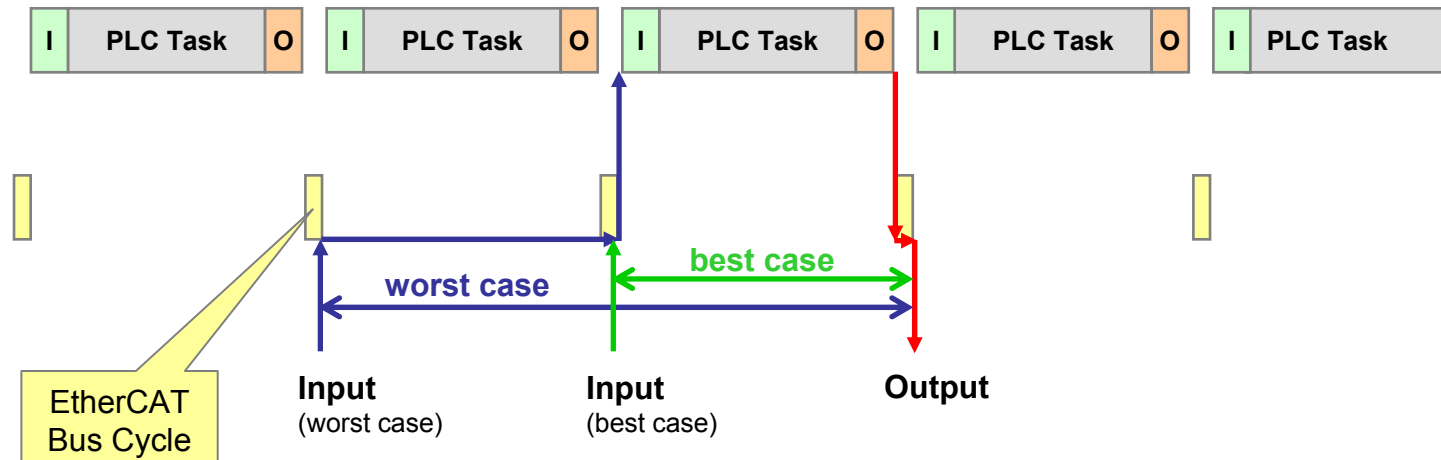

- Reaction time reduced significantly with the same controller performance
- no underlying local I/O cycles and extension bus delays any more
- Due to the very simple protocol no dedicated master systems (e.g. plug-in cards) required

Fieldbus: requires Mapping in Control System

EtherCAT is:

- Faster
- Synchronization
- Industrial Ethernet
- Flexible
- Easier to configure
- Cost effective
- Easier to implement
- Well proven
- Open
- Conformance
- Safety
- Redundancy
- Versatile

- Traditional fieldbus system generate physical process image
- This has to be mapped to logical process image(s)
 - Resorting of process data is required, too - even if only one process image (e.g. only NC data) is used!

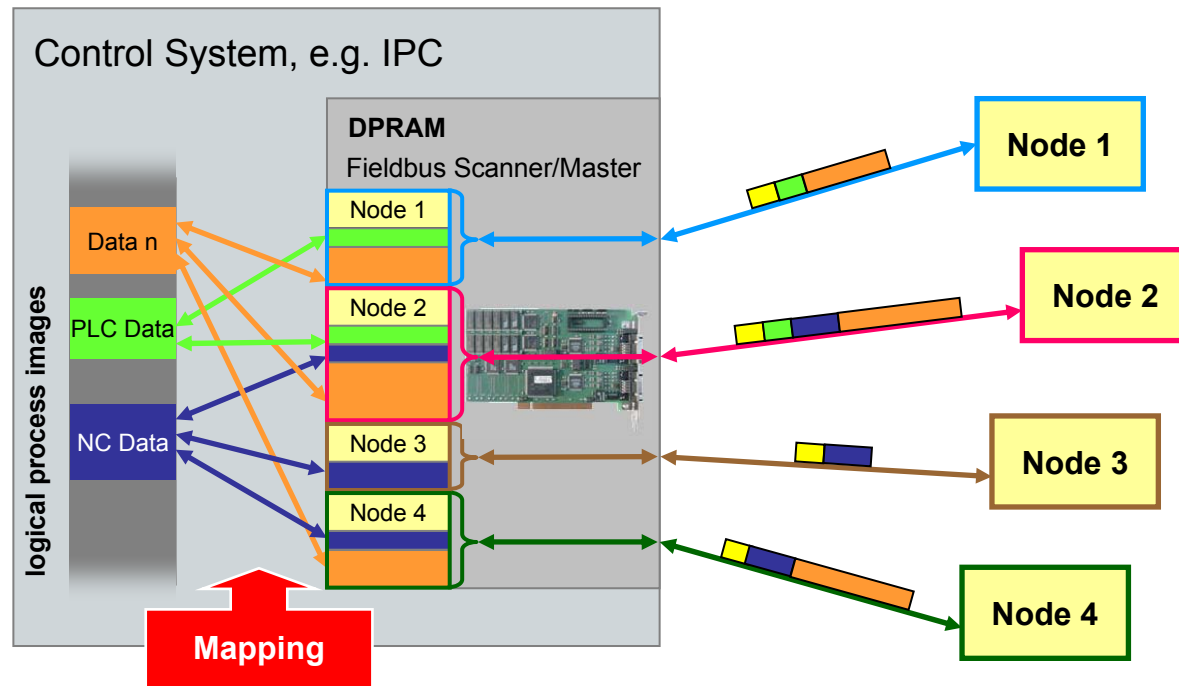

EtherCAT is:

- Faster
- Synchronization
- Industrial Ethernet
- Flexible
- Easier to configure
- Cost effective
- Easier to implement
- Well proven
- Open
- Conformance
- Safety
- Redundancy
- Versatile

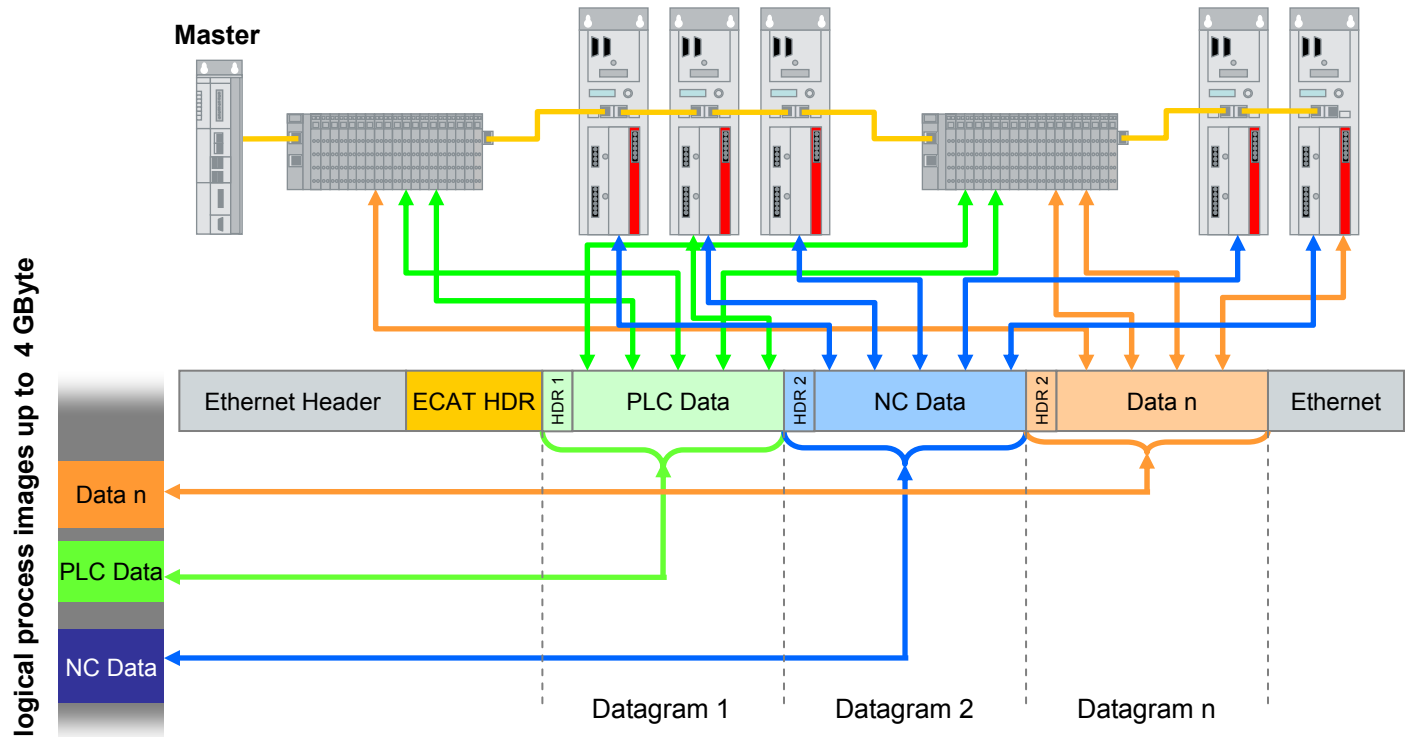

- Control System is unburdened, master becomes very simple
- Data is transmitted according to the application requirements: extremely fast, flexibly and efficiently

Direct Memory Access saves time

EtherCAT is:

- Faster
- Synchronization
- Industrial Ethernet
- Flexible
- Easier to configure
- Cost effective
- Easier to implement
- Well proven
- Open
- Conformance
- Safety
- Redundancy
- Versatile

- **Fieldbus cards:**
up to 30% of CPU
time for data
copying

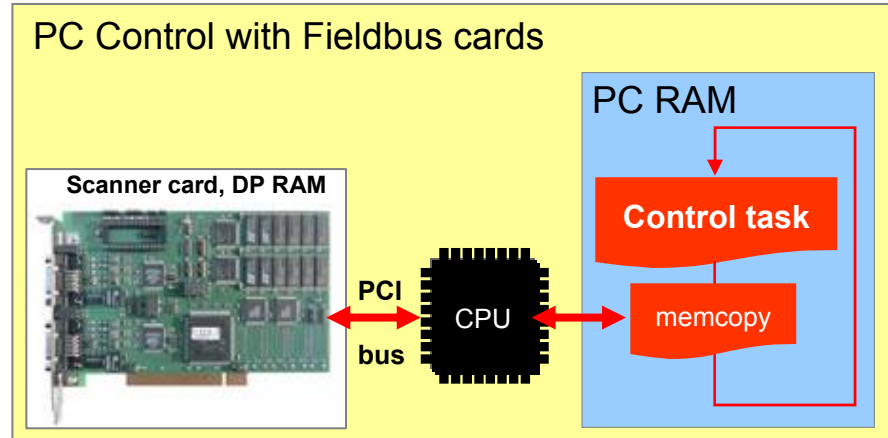

- **EtherCAT:**
MAC is PCI Bus
master, data is
provided by DMA
directly to PC RAM:
CPU relieved more
performance

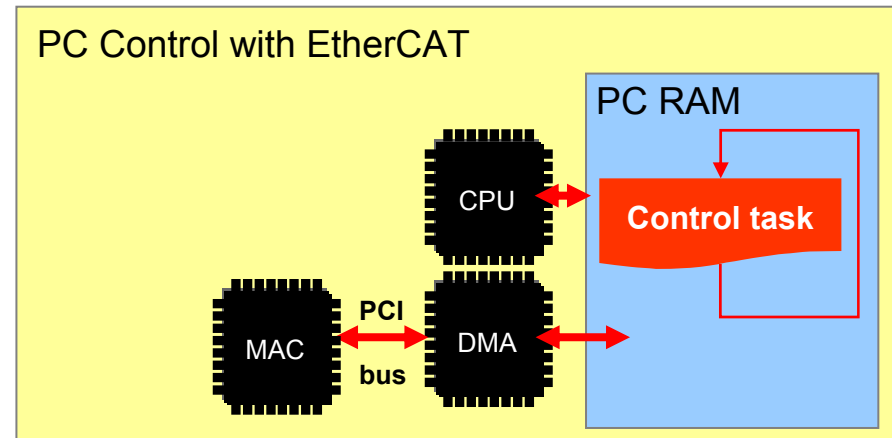

EtherCAT is:

- Faster ✓
- Synchronization
- Industrial Ethernet
- Flexible
- Easier to configure
- Cost effective
- Easier to implement
- Well proven
- Open
- Conformance
- Safety
- Redundancy
- Versatile

- EtherCAT Node measures time difference between leaving and returning frame

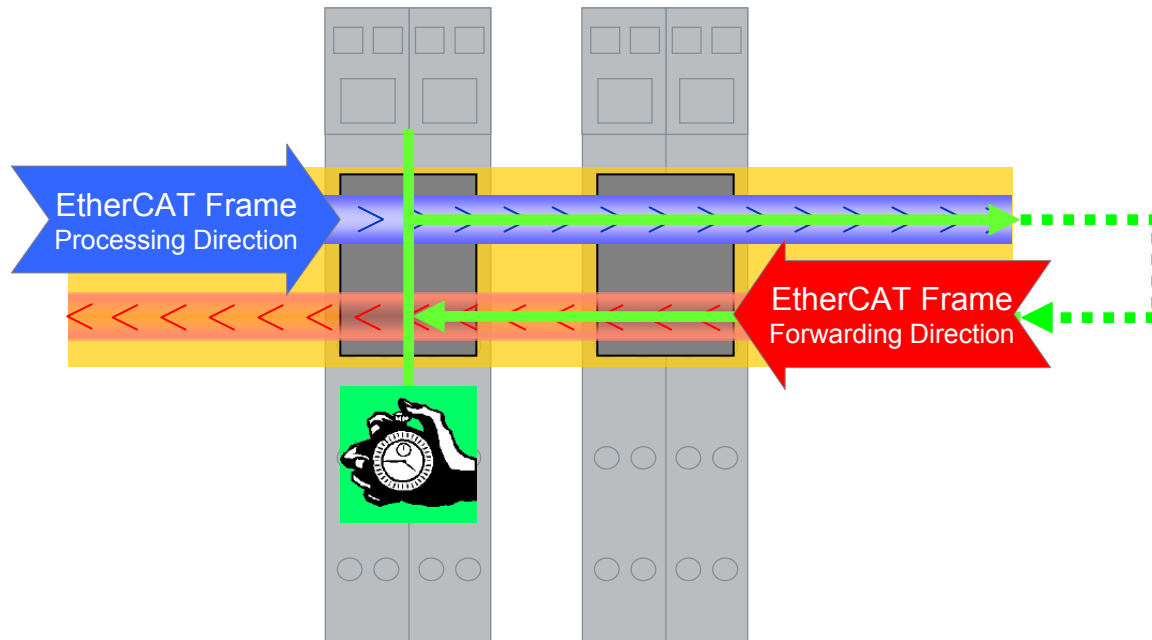

EtherCAT is:

- Faster ✓
- Synchronization
- Industrial Ethernet
- Flexible
- Easier to configure
- Cost effective
- Easier to implement
- Well proven
- Open
- Conformance
- Safety
- Redundancy
- Versatile

- EtherCAT Node measures time difference between leaving and returning frame

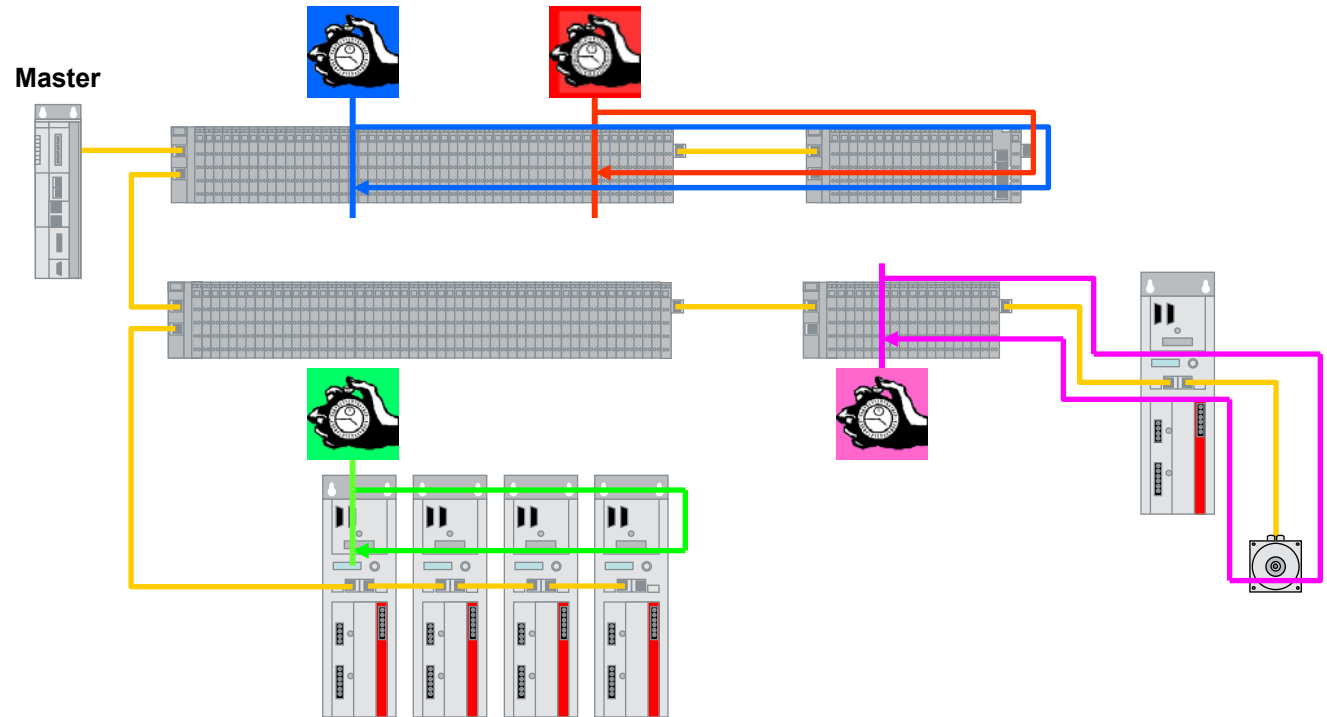

Distributed Clocks

EtherCAT is:

- Faster ✓
- Synchronization
- Industrial Ethernet
- Flexible
- Easier to configure
- Cost effective
- Easier to implement
- Well proven
- Open
- Conformance
- Safety
- Redundancy
- Versatile

- Precise Synchronization ($\ll 1 \mu\text{s}$!) by exact adjustment of Distributed Clocks

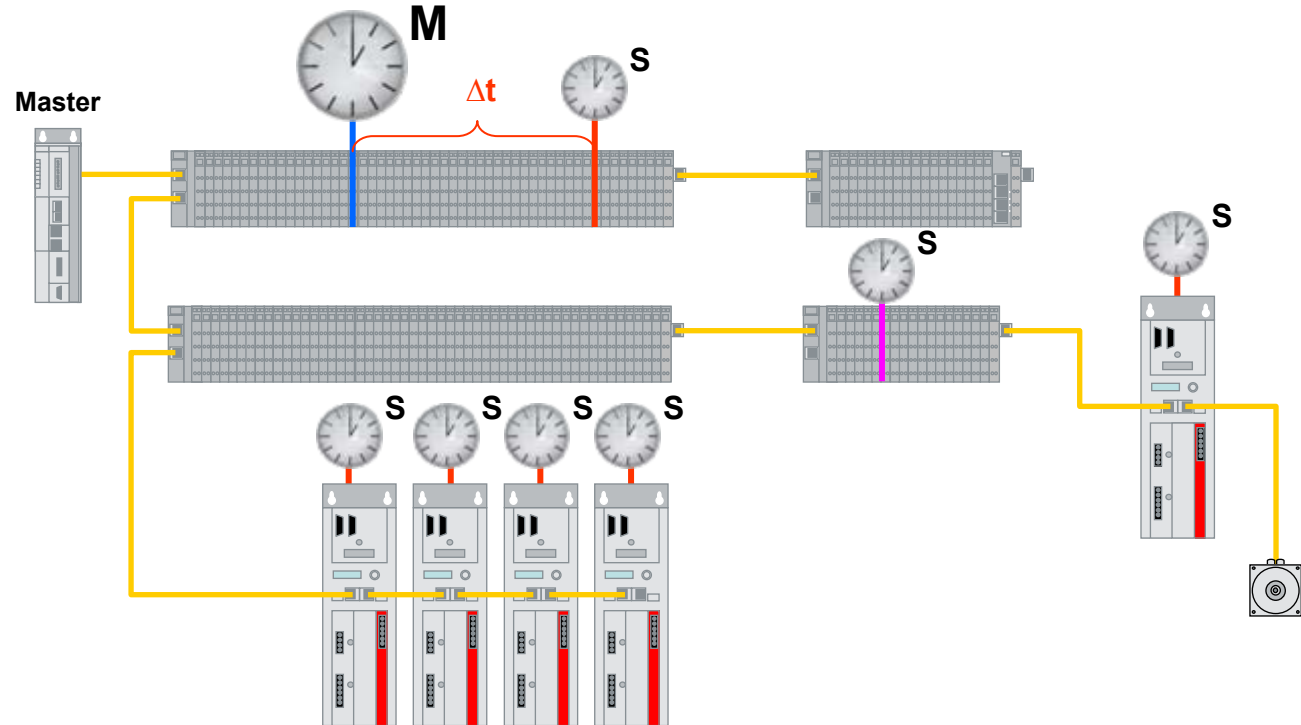

Distributed Clocks

EtherCAT is:

- Faster ✓
- Synchronization
- Industrial Ethernet
- Flexible
- Easier to configure
- Cost effective
- Easier to implement
- Well proven
- Open
- Conformance
- Safety
- Redundancy
- Versatile

- Long Term Scope View of two separated devices
- 300 Nodes in between, 120m Cable Length

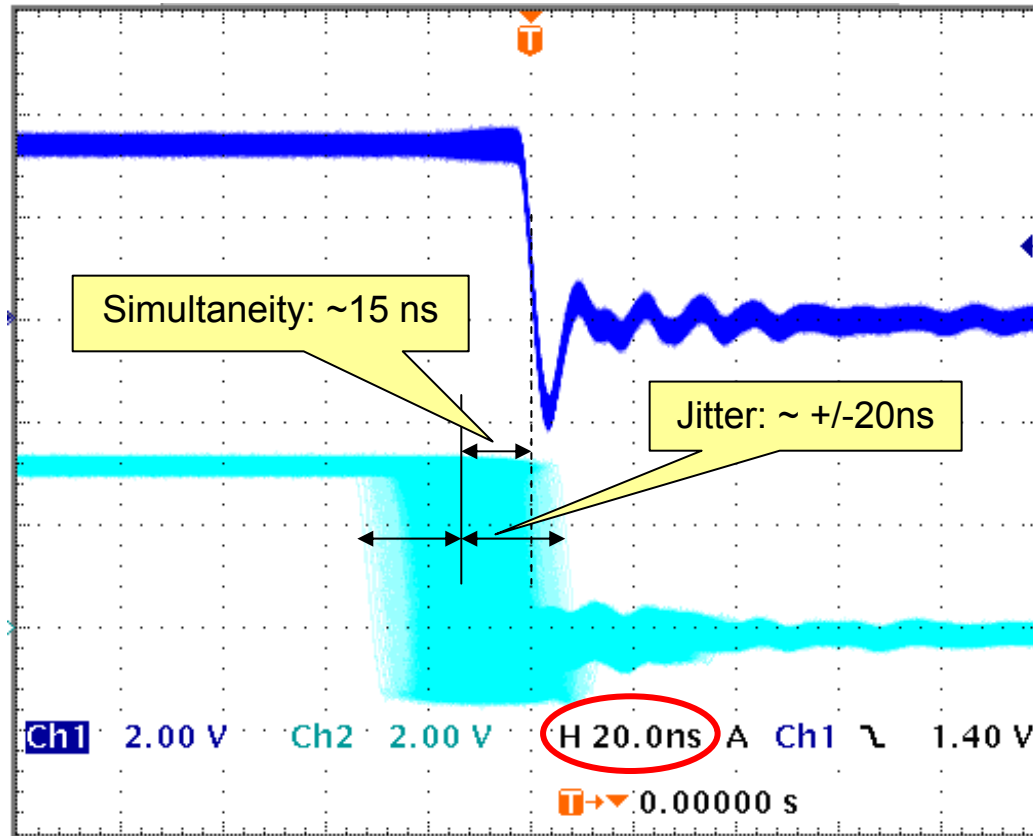

EtherCAT is Industrial Ethernet!

EtherCAT is:

- Faster ✓
- Synchronization ✓
- Industrial Ethernet
- Flexible
- Easier to configure
- Cost effective
- Easier to implement
- Well proven
- Open
- Conformance
- Safety
- Redundancy
- Versatile

- EtherCAT uses Standard Ethernet Frames: IEEE 802.3
- Alternatively via UDP/IP (if IP Routing is needed)
- no shortened frames

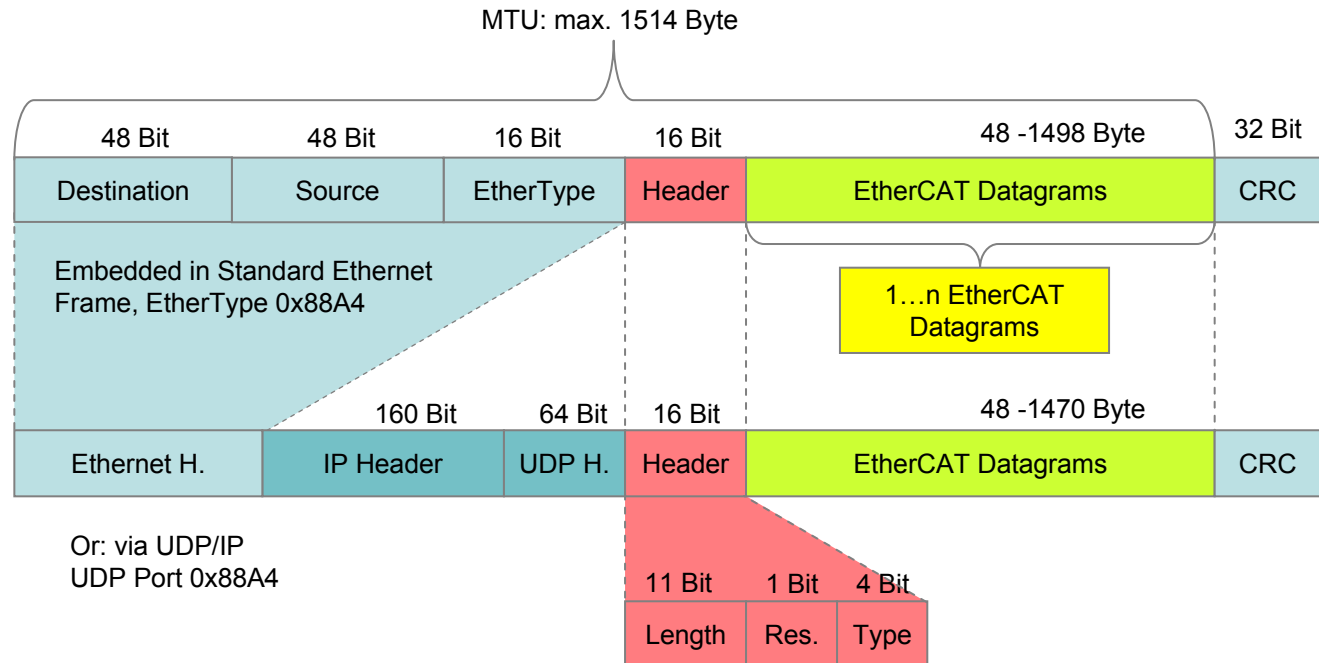

EtherCAT is Industrial Ethernet!

EtherCAT is:

- Faster ✓
- Synchronization ✓
- Industrial Ethernet
- Flexible
- Easier to configure
- Cost effective
- Easier to implement
- Well proven
- Open
- Conformance
- Safety
- Redundancy
- Versatile

- fully transparent for TCP/IP
- all Internet technologies (HTTP, FTP, Webserver,...) available without restricting the real time capabilities!
- full tool access to devices at real time operation – with and without TCP/IP

Standard TCP/IP Stack

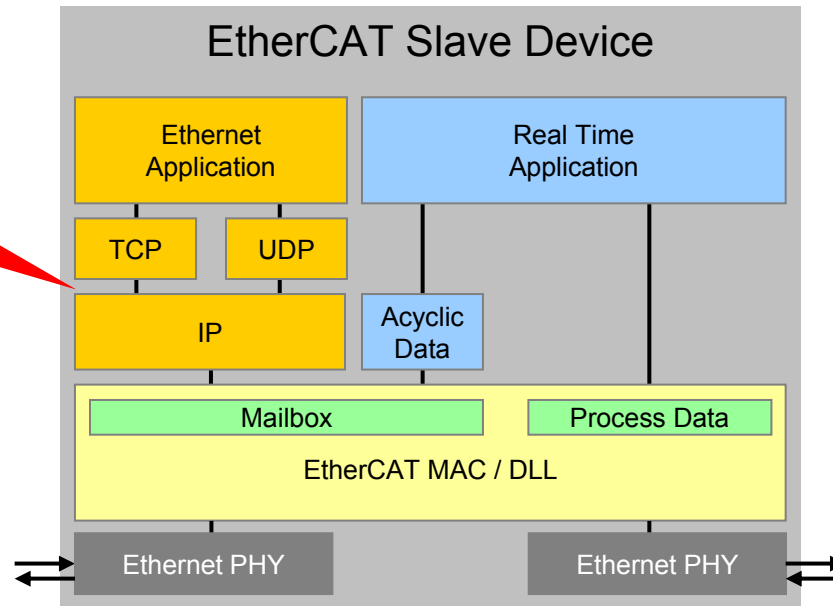

EtherCAT is Industrial Ethernet!

EtherCAT is:

- Faster ✓
- Synchronization ✓

- Industrial Ethernet

- Flexible
- Easier to configure
- Cost effective
- Easier to implement
- Well proven
- Open
- Conformance
- Safety
- Redundancy
- Versatile

- Any Ethernet Device can be connected to Switchport
- Access to Webserver with Standard Browser

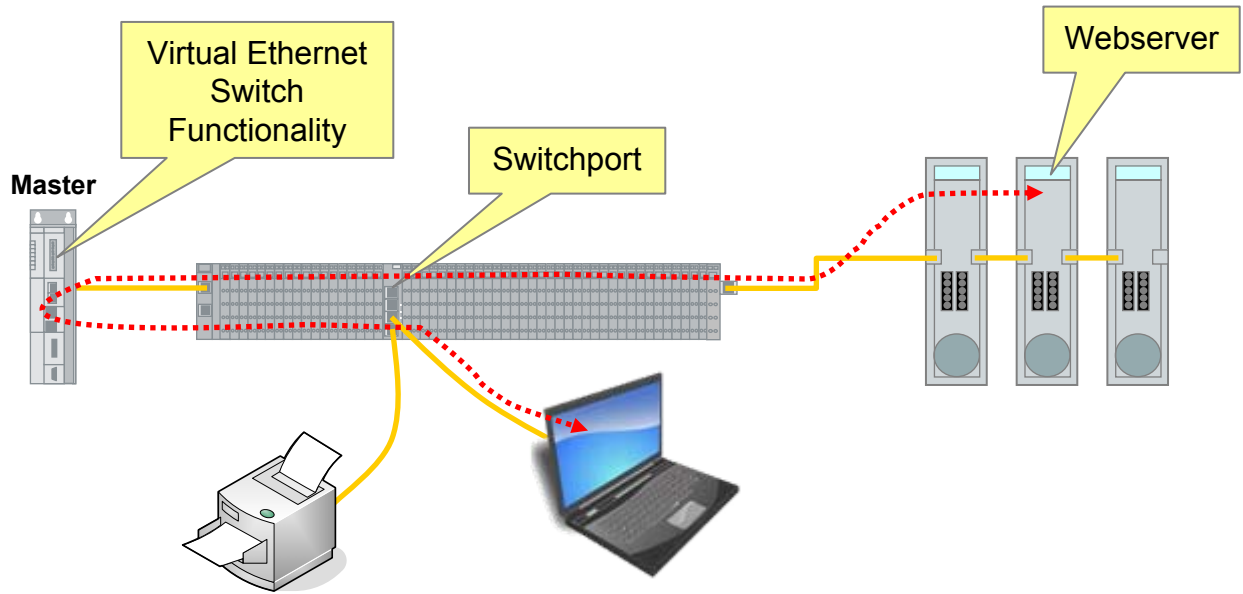

EtherCAT is Industrial Ethernet!

EtherCAT is:

- Faster ✓
- Synchronization ✓

- Industrial Ethernet

- Flexible
- Easier to configure
- Cost effective
- Easier to implement
- Well proven
- Open
- Conformance
- Safety
- Redundancy
- Versatile

- Virtual Ethernet Switch routes any Ethernet Frame
- From inside as well as from outside the segment

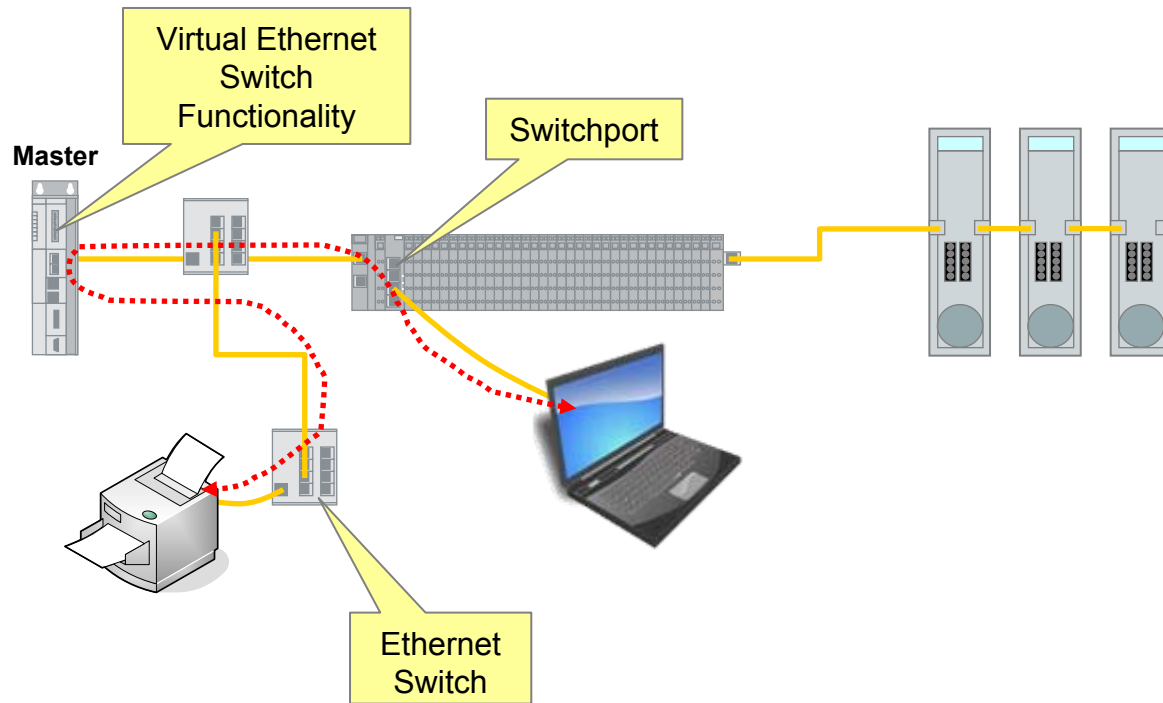

Switchport: Any Ethernet Protocol

EtherCAT is:

- Faster ✓
- Synchronization ✓
- Industrial Ethernet
- Flexible
- Easier to configure
- Cost effective
- Easier to implement
- Well proven
- Open
- Conformance
- Safety
- Redundancy
- Versatile

- Interface to any Ethernet Device or Network
- Ethernet Frames are inserted into EtherCAT Protocol:
 - 'Ethernet over EtherCAT'

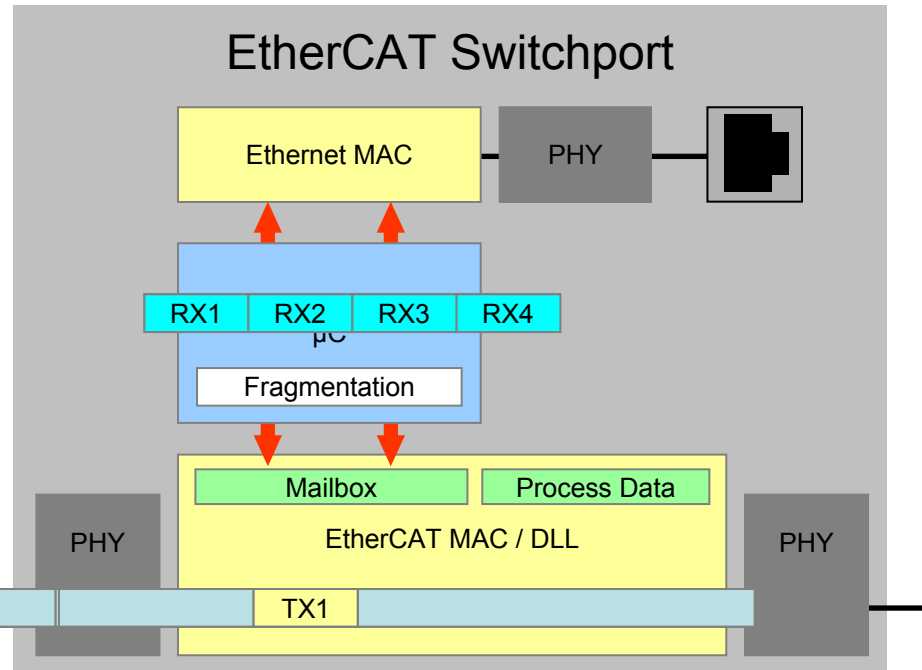

Vertical Integration (1)

EtherCAT is:

- Faster ✓
- Synchronization ✓
- Industrial Ethernet
- Flexible
- Easier to configure
- Cost effective
- Easier to implement
- Well proven
- Open
- Conformance
- Safety
- Redundancy
- Versatile

- ...via Switchport

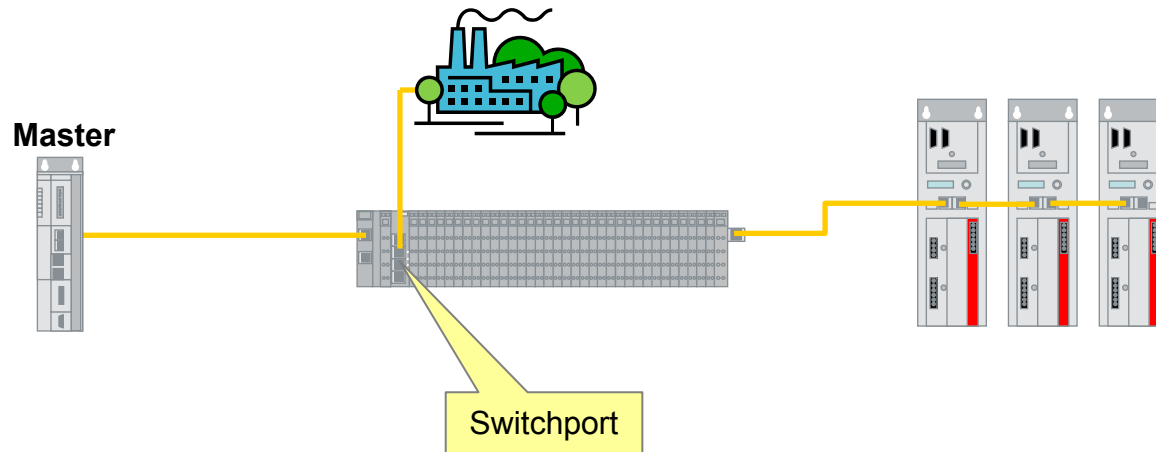

- + any Ethernet Protocol can be used
- + requires only one Ethernet Port (at IPC/Controller)
- + EtherCAT performance is not limited

Vertical Integration (2)

EtherCAT is:

- Faster ✓
- Synchronization ✓
- Industrial Ethernet
- Flexible
- Easier to configure
- Cost effective
- Easier to implement
- Well proven
- Open
- Conformance
- Safety
- Redundancy
- Versatile

- ...via 2. Ethernet Port

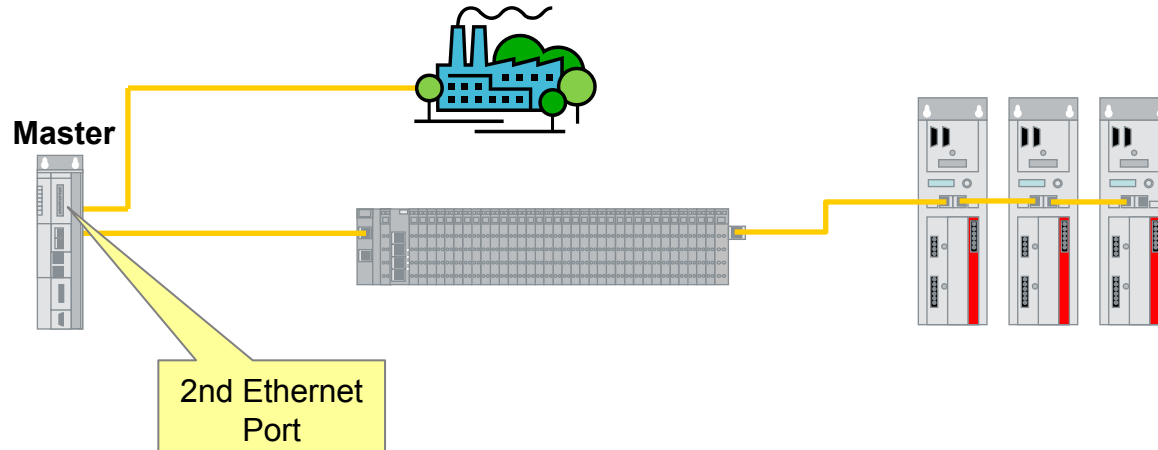

- + any Ethernet Protocol can be used
- + EtherCAT performance is not limited
- but: requires second Ethernet Port (at IPC/Controller)

Vertical Integration (3)

EtherCAT is:

- Faster ✓
- Synchronization ✓
- Industrial Ethernet
- Flexible
- Easier to configure
- Cost effective
- Easier to implement
- Well proven
- Open
- Conformance
- Safety
- Redundancy
- Versatile

- ...via Switch

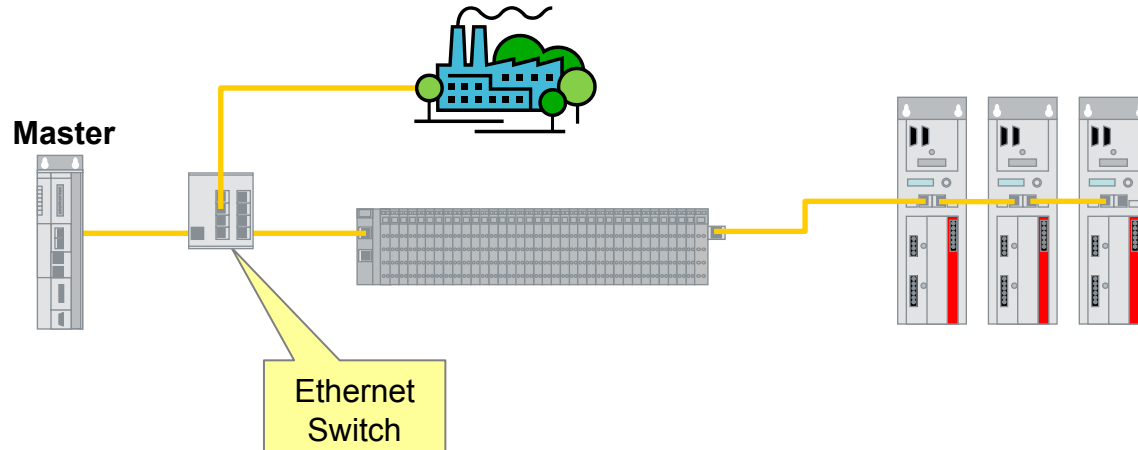

- + any Ethernet Protocol can be used
- + requires only one Ethernet Port (at IPC/Controller)
- but: performance reduced by switch delay (and generic Ethernet traffic)

EtherCAT is:

- Faster ✓
- Synchronization ✓
- Industrial Ethernet ✓
- Flexible
- Easier to configure
- Cost effective
- Easier to implement
- Well proven
- Open
- Conformance
- Safety
- Redundancy
- Versatile

- Standard Ethernet Topology: Star



EtherCAT wiring is more flexible

EtherCAT is:

- Faster ✓
- Synchronization ✓
- Industrial Ethernet ✓
- Flexible
- Easier to configure
- Cost effective
- Easier to implement
- Well proven
- Open
- Conformance
- Safety
- Redundancy
- Versatile

- Flexible tree structures – arbitrarily extendable
 - Topology variants like Line, Star, Tree, Daisy Chain + Drop Lines possible; can be used in any combination!
 - Up to 65.535 nodes for each EtherCAT segment
 - Standard Ethernet cabling

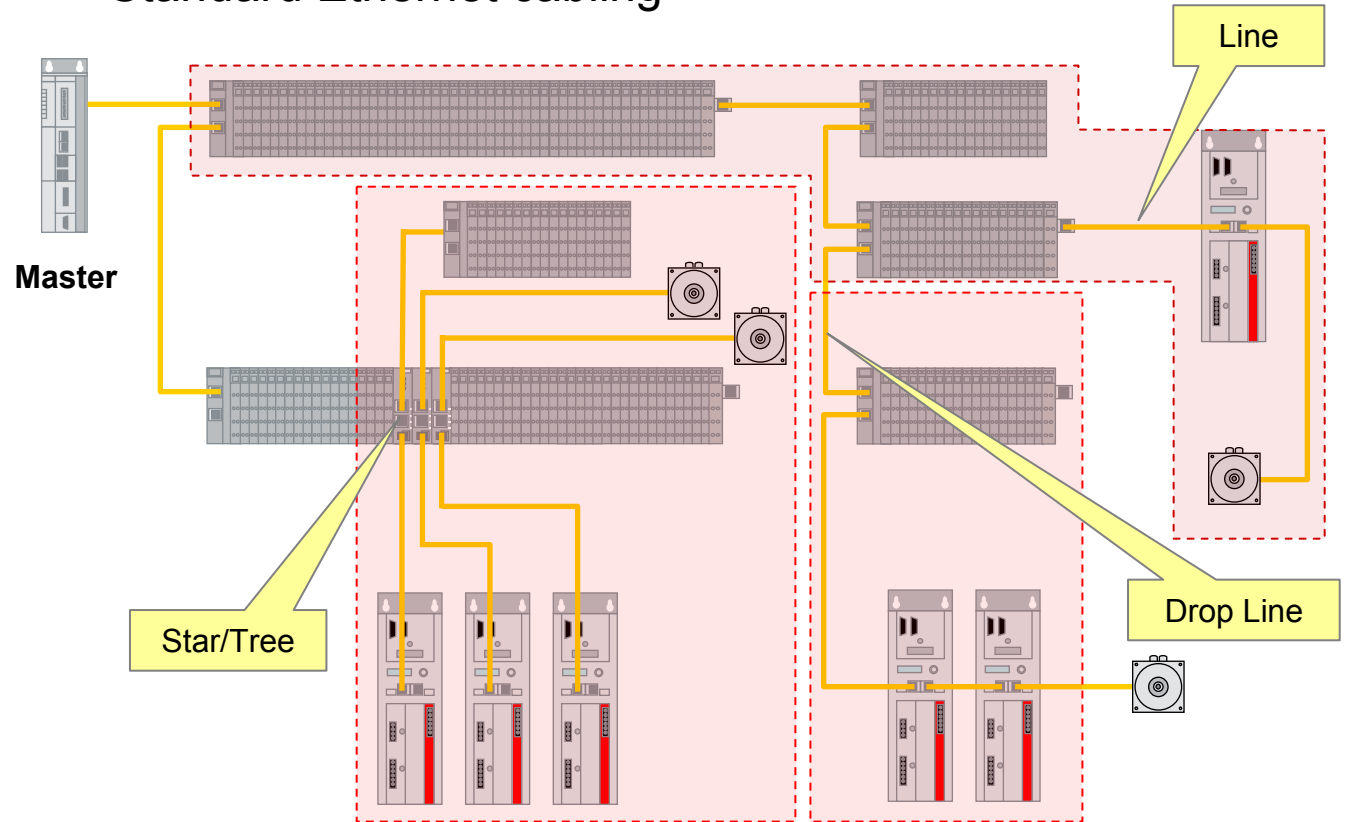

EtherCAT wiring is more flexible

EtherCAT is:

- Faster ✓
- Synchronization ✓
- Industrial Ethernet ✓
- Flexible
- Easier to configure
- Cost effective
- Easier to implement
- Well proven
- Open
- Conformance
- Safety
- Redundancy
- Versatile

- Ethernet Signal Variants of EtherCAT:
 - 100BASE-TX (up to 100 m between 2 nodes)
 - 100BASE-FX (up to 2 km between 2 nodes)
 - LVDS (for modular devices)

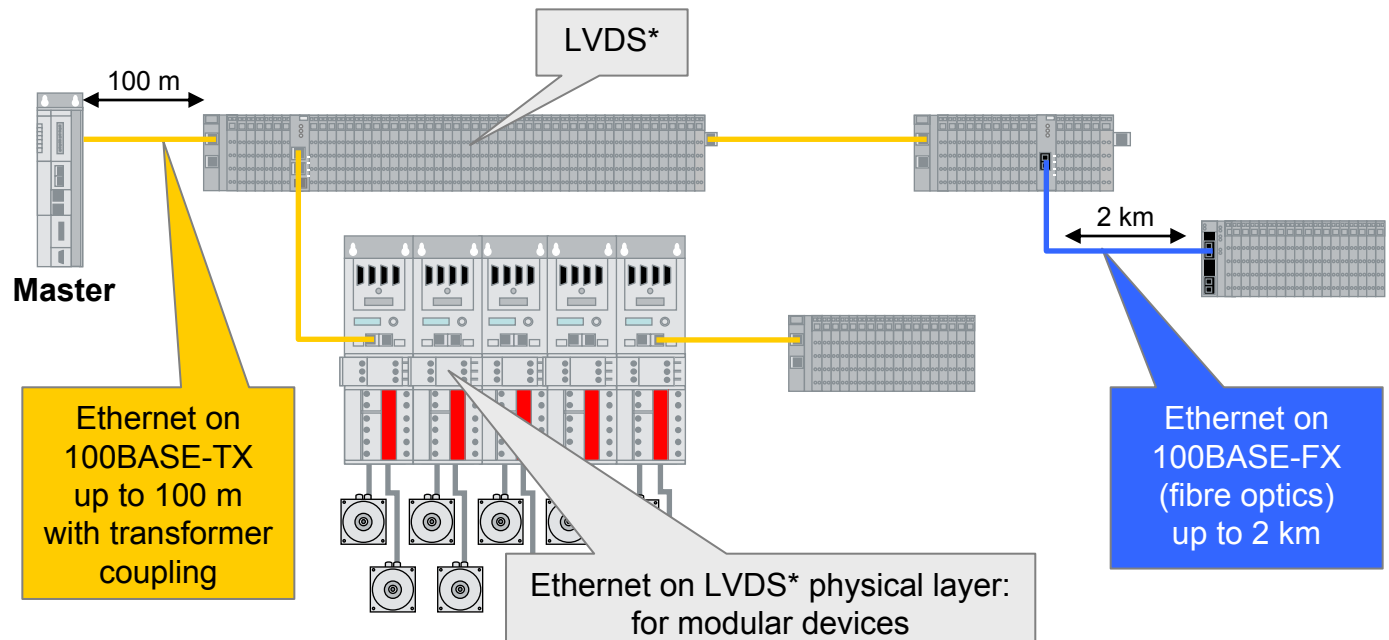

- Any number of physical layer changes allowed

*LVDS: Low Voltage Differential Signaling according to ANSI/TIA/EIA-644, also used in IEEE 802.3ae (10Gigabit Ethernet)

EtherCAT is:

- Faster ✓
- Synchronization ✓
- Industrial Ethernet ✓
- Flexible
- Easier to configure
- Cost effective
- Easier to implement
- Well proven
- Open
- Conformance
- Safety
- Redundancy
- Versatile



**10.056
EtherCAT Nodes**

EtherCAT instead of PCI

EtherCAT is:

- Faster ✓
- Synchronization ✓
- Industrial Ethernet ✓
- Flexible
- Easier to configure
- Cost effective
- Easier to implement
- Well proven
- Open
- Conformance
- Safety
- Redundancy
- Versatile

- Protection of your investment
- smooth migration path from legacy fieldbus to EtherCAT
- seamless integration of existing fieldbus devices, e.g.:

- AS-Interface
- CANopen
- CC-Link
- ControlNet
- DeviceNet
- Ethernet/IP
- FIPIO
- Interbus
- IO-Link
- Lightbus
- LonWorks
- Modbus Plus, RTU, TCP
- PROFIBUS
- PROFINET IO
- ...

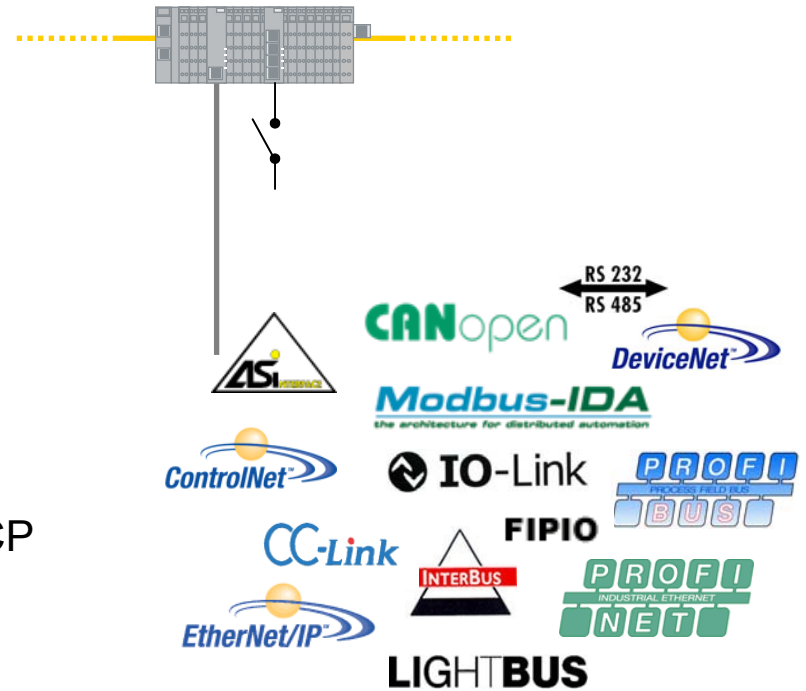

- maximum system expandability with low cost fieldbus gateways

EtherCAT instead of PCI

EtherCAT is:

- Faster ✓
- Synchronization ✓
- Industrial Ethernet ✓
- Flexible
- Easier to configure
- Cost effective
- Easier to implement
- Well proven
- Open
- Conformance
- Safety
- Redundancy
- Versatile

- Update Times:
 - Process image update-time via PCI (**500 Bytes** input and output data each): **400 μs**
 - Process image update-time via EtherCAT (**1.500 Bytes** input and output data): **150 μs**

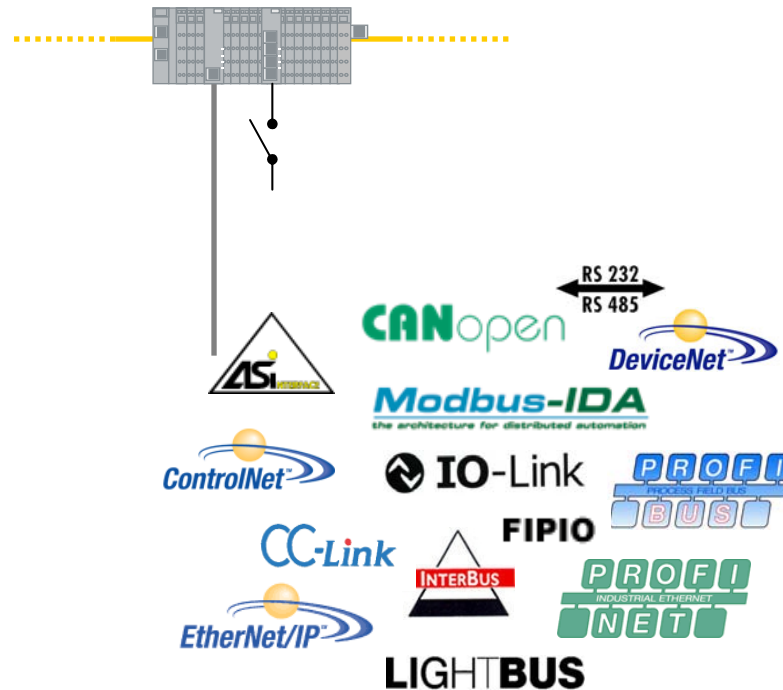

EtherCAT instead of PCI

EtherCAT is:

- Faster ✓
- Synchronization ✓
- Industrial Ethernet ✓
- Flexible
- Easier to configure
- Cost effective
- Easier to implement
- Well proven
- Open
- Conformance
- Safety
- Redundancy
- Versatile

- No Slots in Control System (IPC or PLC) required any more
- Nevertheless maximum expandability

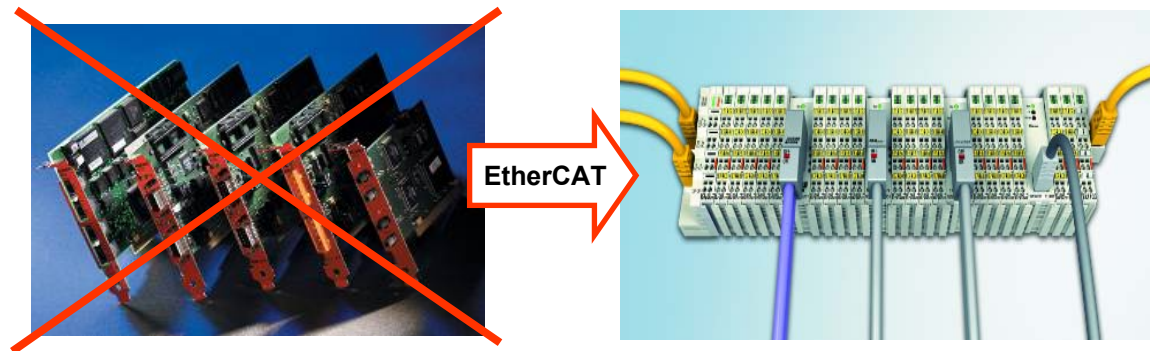



EtherCAT is:

- Faster ✓
- Synchronization ✓
- Industrial Ethernet ✓
- Flexible ✓
- Easier to configure
- Cost effective
- Easier to implement
- Well proven
- Open
- Conformance
- Safety
- Redundancy
- Versatile

- **Topology:**
 - Automatic topology target/actual comparison
- **Diagnosis:**
 - Diagnosis with exact localization
- **Network planning:**
 - Performance independent of:
 - Slave implementation
 - Topology (no Switches/Hubs)
- **Addressing**
 - No manual address setting required
 - Addresses can be assigned automatically
 - Addresses can be kept
 - no new addressing if nodes are added





EtherCAT is:

- Faster ✓
- Synchronization ✓
- Industrial Ethernet ✓
- Flexible ✓
- Easier to configure ✓
- Cost effective
- Easier to implement
- Well proven
- Open
- Conformance
- Safety
- Redundancy
- Versatile

- Implementation / Tools:
 - Standard Network Monitor Tools, e.g. MS Network Monitor or Wireshark: free of charge
 - Parser Software: free of charge
- Less effort for Network planning:
 - Simplified configuration
 - Default settings will work, no network tuning
- Improved Diagnosis:
 - Faster error handling leads to less downtime
- Faster Setup:
 - No address setting required



EtherCAT is:

- Faster ✓
- Synchronization ✓
- Industrial Ethernet ✓
- Flexible ✓
- Easier to configure ✓
- Cost effective
- Easier to implement
- Well proven
- Open
- Conformance
- Safety
- Redundancy
- Versatile

- **Master:**
 - no dedicated plug in card (co-processor)
 - on-board Ethernet Port is fine
- **Slave:**
 - low cost Slave Controller
 - FPGA or ASIC
 - for simple devices: no μ C needed
 - no powerful μ C needed
- **Infrastructure:**
 - no Switches/Hubs required
 - Standard Ethernet Cabling + Connectors

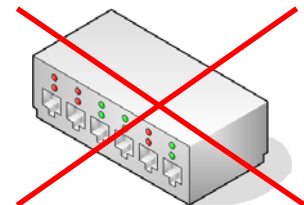
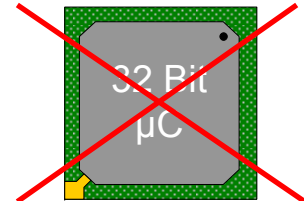





EtherCAT is:

- Faster ✓
- Synchronization ✓
- Industrial Ethernet ✓
- Flexible ✓
- Easier to configure ✓
- Cost effective ✓
- Easier to implement
- Well proven
- Open
- Conformance
- Safety
- Redundancy
- Versatile

- **Slave Implementation:**
 - All time critical functions implemented on ASIC or FPGA
 - ESC handles Real-time Protocol in Hardware
 - Integrated Communication State Machine
 - Network Performance independent of
 - Slave- μ C Performance
 - Protocol Stack
 - For usage with or without μ C (Host CPU)
 - Integrated DPRAM (1...8kByte)
 - Integrated Distributed Clock Handling
 - Ultra precise interrupts to μ C

EtherCAT is:







- Faster ✓
- Synchronization ✓
- Industrial Ethernet ✓
- Flexible ✓
- Easier to configure ✓
- Cost effective ✓
- Easier to implement
- Well proven
- Open
- Conformance
- Safety
- Redundancy
- Versatile

Name	ET1100 	ET1200 	netX5 
Type	ASIC	ASIC	ASIC
Hardware Supplier	BECKHOFF	BECKHOFF	
Package	BGA128 0,8mm Pitch	QFN48 0,5mm Pitch	BGA201 0,8mm Pitch
Size	10 x 10 mm	7 x 7 mm	13 x 13 mm
µC Interface	serial/parallel (8/16-bit, async)*	serial*	serial (SPI), parallel (8/16/32-bit, async)
Digital I/O	32	8-16*	16
DPRAM	8 kByte	1 kByte	6 kByte
SyncManager	8	4	8
FMMUs	8	3	8
Distributed Clocks	Yes	Yes	Yes
No. Of Ports	2-4 (MII/E-bus)*	2-3 (E-bus/max. 1xMII)*	2 (MII)
Specials	Routable with standard PCB	-	Multi Protocol Support

* configurable



EtherCAT is:

- Faster ✓
- Synchronization ✓
- Industrial Ethernet ✓
- Flexible ✓
- Easier to configure ✓
- Cost effective ✓
- Easier to implement
- Well proven
- Open
- Conformance
- Safety
- Redundancy
- Versatile

Name	netX 100 	netX 500 	netX50 
Type	ASIC	ASIC	ASIC
Hardware Supplier			
Package	BGA345 1mm Pitch	BGA345 1mm Pitch	PBGA 1mm Pitch
Size	22x22 mm	22x22 mm	19x19 mm
µC Interface	µC-Bus (internal, 32-bit)	µC-Bus (internal, 32-bit)	µC-Bus (internal, 32-bit)
Digital I/O	16 (GPIO)	16 (GPIO)	32 (GPIO)
DPRAM	256/400 Byte (Mailbox/Process Data)	256/400 Byte (Mailbox/Process Data)	6 kByte
SyncManager	4	4	8
FMMUs	3	3	8
Distributed Clocks	Yes	Yes	Yes
No. Of Ports	2 (100BASE-TX)	2 (100BASE-TX)	2 (100BASE-TX)
Specials	Multi Protocol Support, Integrated: PHYs, ARM-9 µC	Multi Protocol Support, Integrated: PHYs, ARM-9 µC	Multi Protocol Support, Integrated: PHYs, ARM-9 µC

EtherCAT is:

- Faster ✓
- Synchronization ✓
- Industrial Ethernet ✓
- Flexible ✓
- Easier to configure ✓
- Cost effective ✓
- Easier to implement
- Well proven
- Open
- Conformance
- Safety
- Redundancy
- Versatile

Name	ET1810/ET1811/ET1812	ET1815/ET1816/ET1817
Type	FPGA + IP Core	FPGA + IP Core
Hardware Supplier		
Supported Chips	Cyclone I+II+III, Stratix I+II+III+IV+GX+II GX, Arria GX	Spartan 3+3E+3A+3AN+3ADSP, Virtex II+II Pro+II Pro X+4+5
Package	FPGA dependent	FPGA dependent
Size	FPGA dependent	FPGA dependent
µC Interface	serial/parallel (8/16-bit, async) AVALON®*	serial/parallel (8/16bit, async) OPB®*
Digital I/O	8-32*	8-32*
DPRAM	1...60 kByte*	1...60 kByte*
SyncManager	0...8*	0...8*
FMMUs	0...8*	0...8*
Distributed Clocks	Yes*	Yes*
No. Of Ports	2 (MII)	2 (MII)
Specials	Several IP Core License models available	Several IP Core License models available

* configurable

EtherCAT is easier to implement: Master

EtherCAT is:

- Faster ✓
- Synchronization ✓
- Industrial Ethernet ✓
- Flexible ✓
- Easier to configure ✓
- Cost effective ✓
- Easier to implement
- Well proven
- Open
- Conformance
- Safety
- Redundancy
- Versatile

- Master Implementation:
 - e.g. with Master Sample Code (Source)
 - EtherCAT Configuration Tool
 - XML Data format of ESI and ENI

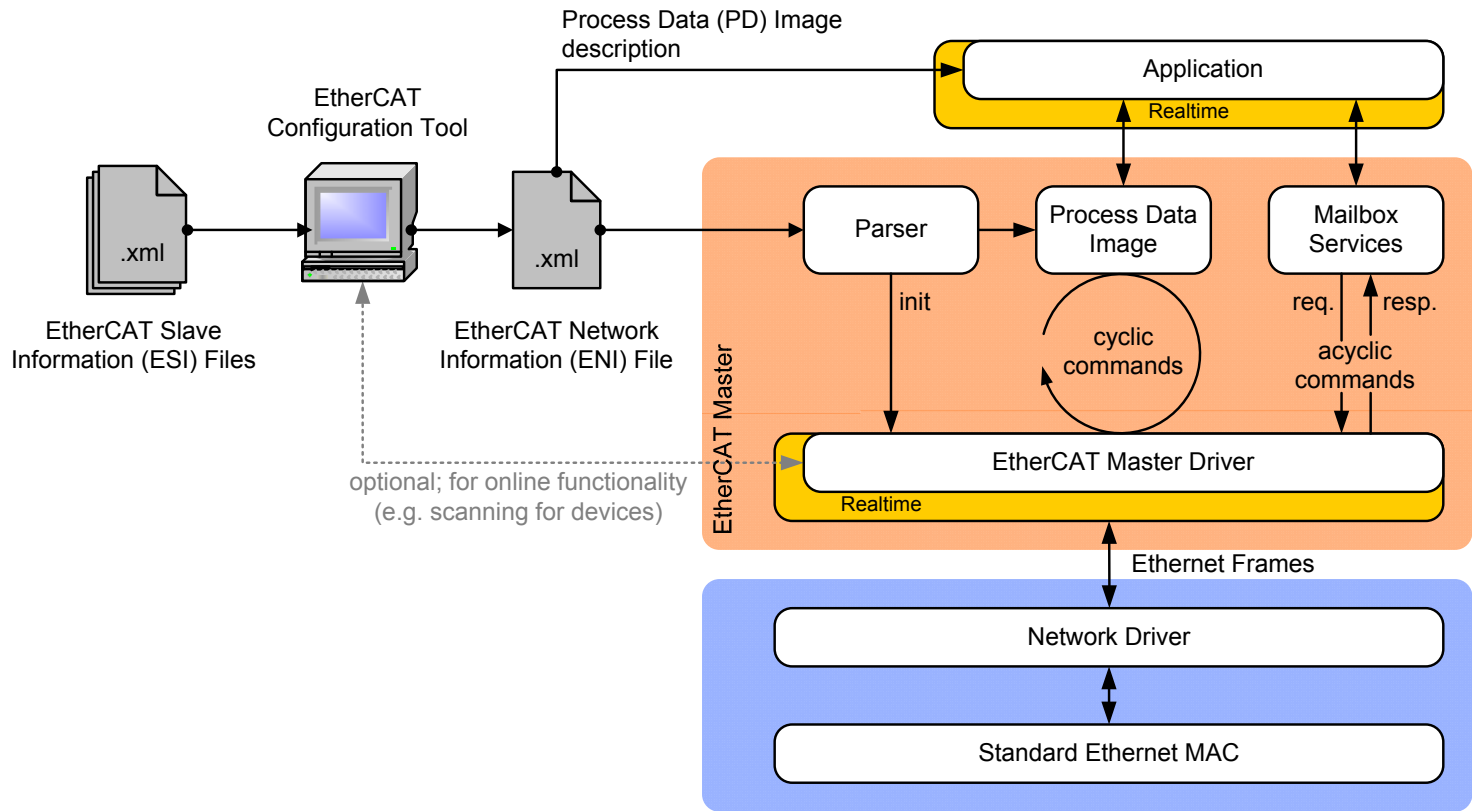

EtherCAT is easier to implement: Master

EtherCAT is:

- Faster ✓
- Synchronization ✓
- Industrial Ethernet ✓
- Flexible ✓
- Easier to configure ✓
- Cost effective ✓
- Easier to implement ✓
- Well proven
- Open
- Conformance
- Safety
- Redundancy
- Versatile

- Example: Master with just one process image
 - typical e.g. for small controllers with one control task
 - up to 1488 Byte Process data size
 - Header for Process Data communication remains constant

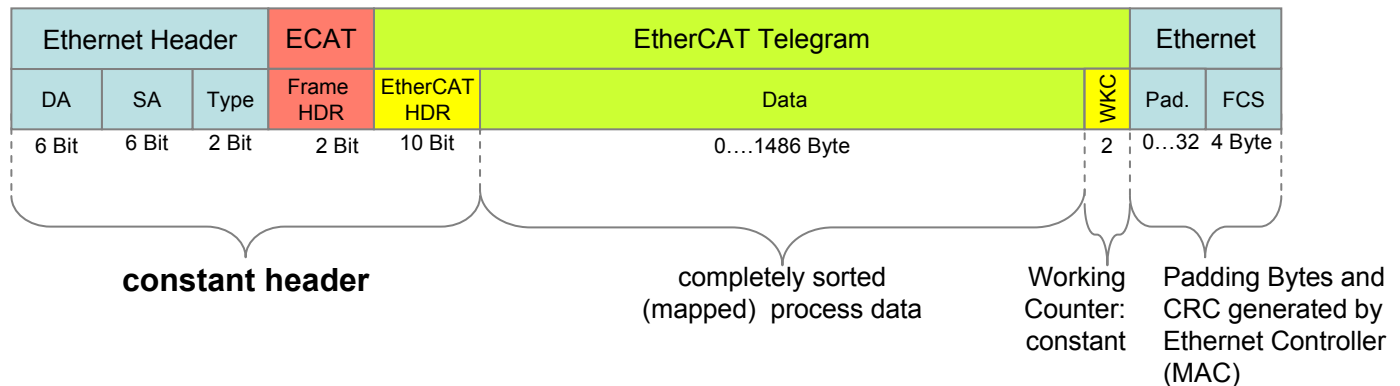

- Master can be implemented with minimal effort
- No separate communication processor required (e.g. on plug-in card)
- Much simpler than legacy fieldbus systems
- Very much simpler than competing Industrial Ethernet approaches...

EtherCAT is well proven

EtherCAT is:

- Faster ✓
 - Synchronization ✓
 - Industrial Ethernet ✓
 - Flexible ✓
 - Easier to configure ✓
 - Cost effective ✓
 - Easier to implement ✓
- Well proven
- Open
 - Conformance
 - Safety
 - Redundancy
 - Versatile

- In series production since 2003
- Numerous applications
- Great product variety of available EtherCAT products



EtherCAT is:

- Faster ✓
- Synchronization ✓
- Industrial Ethernet ✓
- Flexible ✓
- Easier to configure ✓
- Cost effective ✓
- Easier to implement ✓
- Well proven ✓
- Open
- Conformance
- Safety
- Redundancy
- Versatile

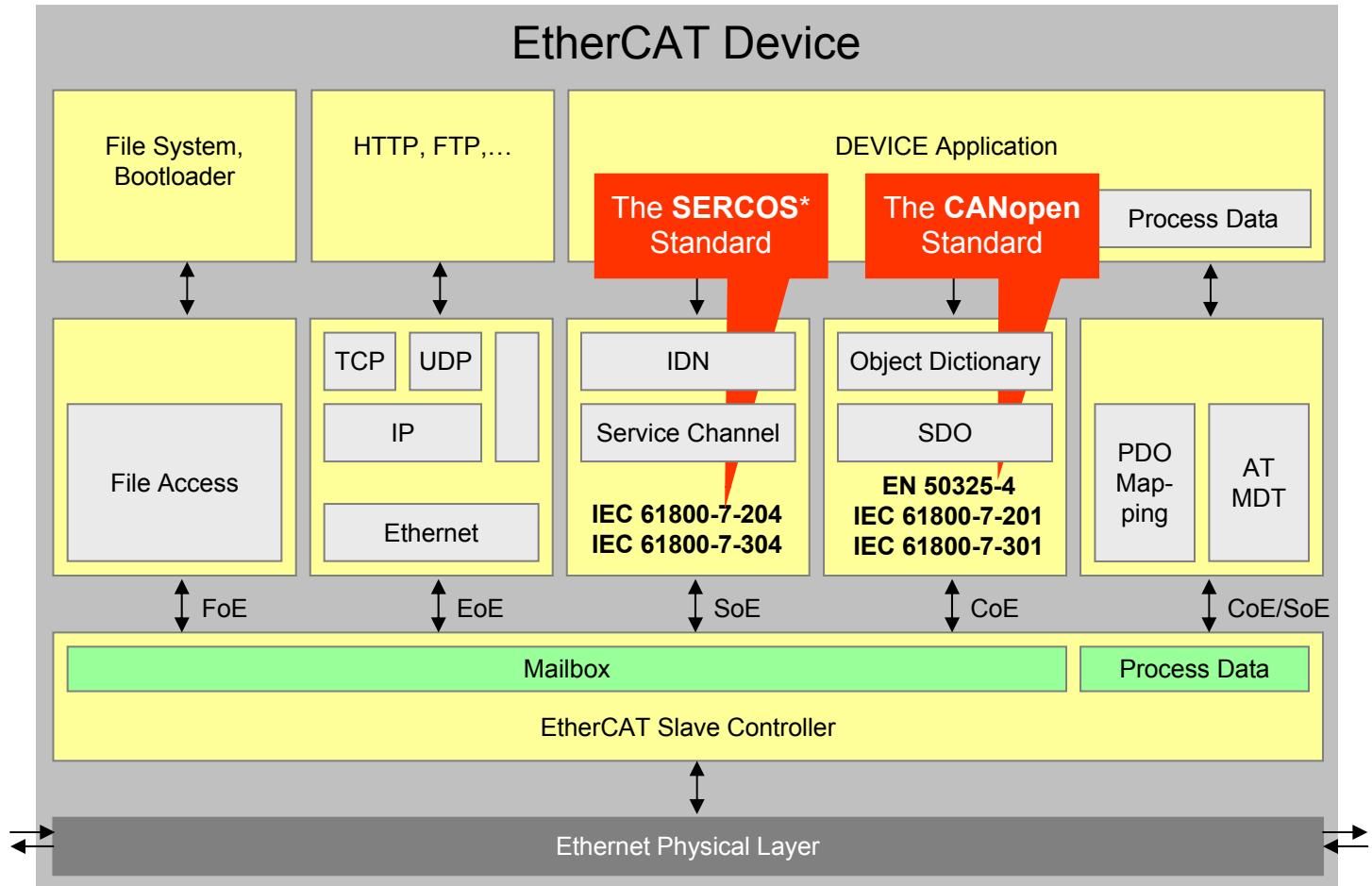

*SERCOS interface™ is a trademark by SI e.V.

Typical EtherCAT Device Architecture

EtherCAT is:

- Faster ✓
- Synchronization ✓
- Industrial Ethernet ✓
- Flexible ✓
- Easier to configure ✓
- Cost effective ✓
- Easier to implement ✓
- Well proven ✓
- Open
- Conformance
- Safety
- Redundancy
- Versatile

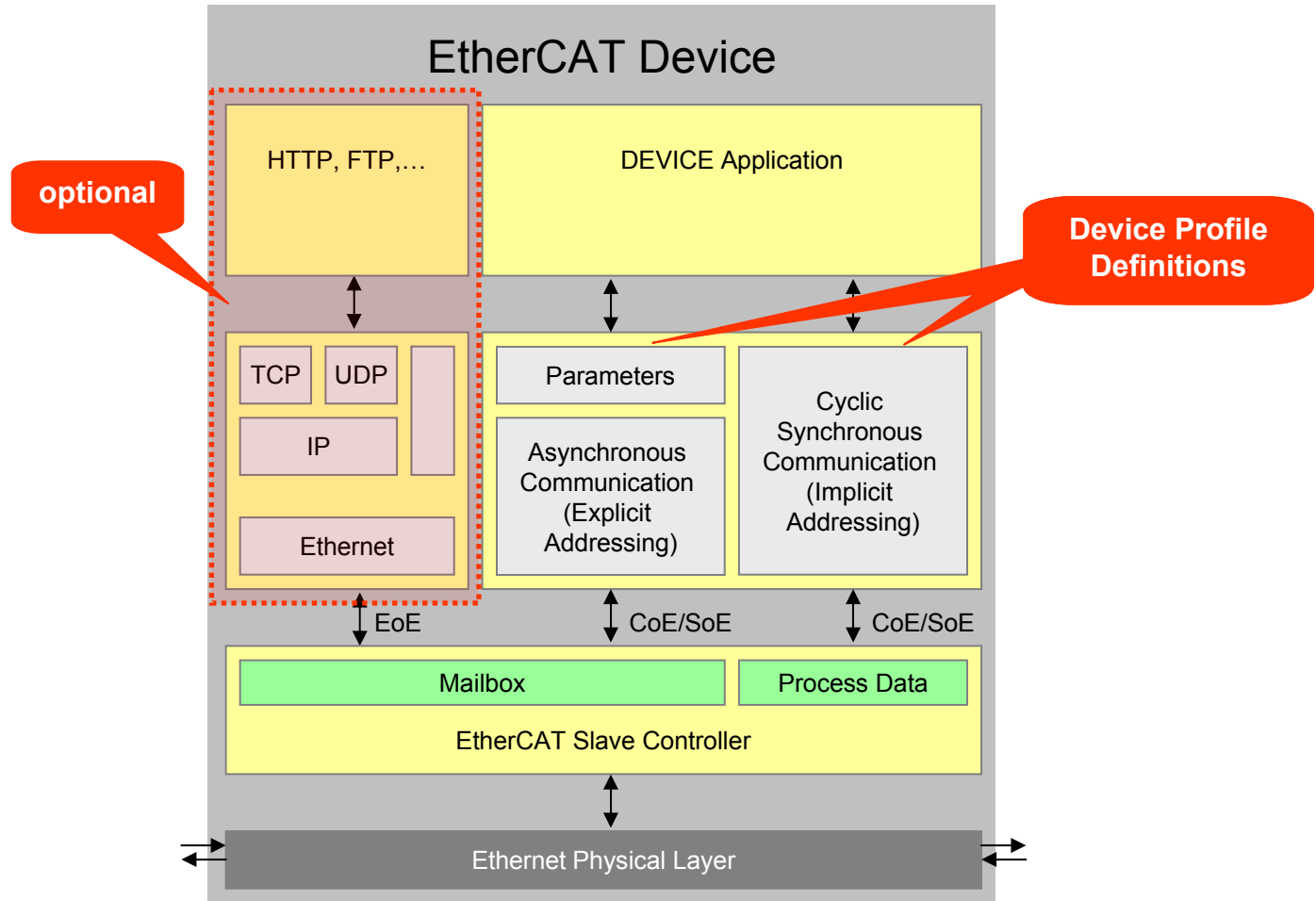

EtherCAT is:

- Faster ✓
- Synchronization ✓
- Industrial Ethernet ✓
- Flexible ✓
- Easier to configure ✓
- Cost effective ✓
- Easier to implement ✓
- Well proven ✓
- Open
- Conformance
- Safety
- Redundancy
- Versatile

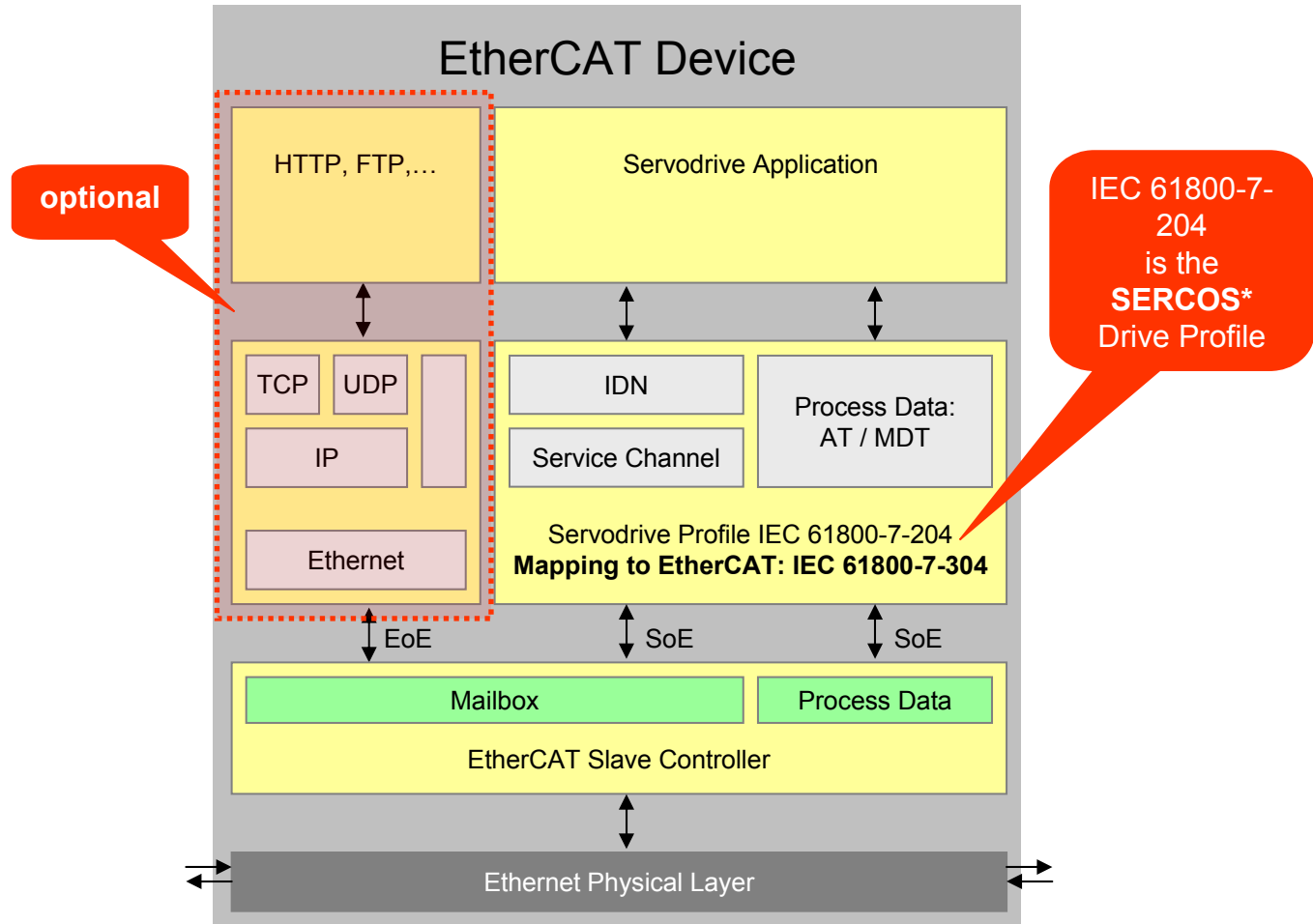

*SERCOS interface™ is a trademark by SI e.V.

EtherCAT is:

- Faster ✓
 - Synchronization ✓
 - Industrial Ethernet ✓
 - Flexible ✓
 - Easier to configure ✓
 - Cost effective ✓
 - Easier to implement ✓
 - Well proven ✓
-
- Open
 - Conformance
 - Safety
 - Redundancy
 - Versatile

IEC 61800-7: Generic Interface and use of profiles for power drive systems

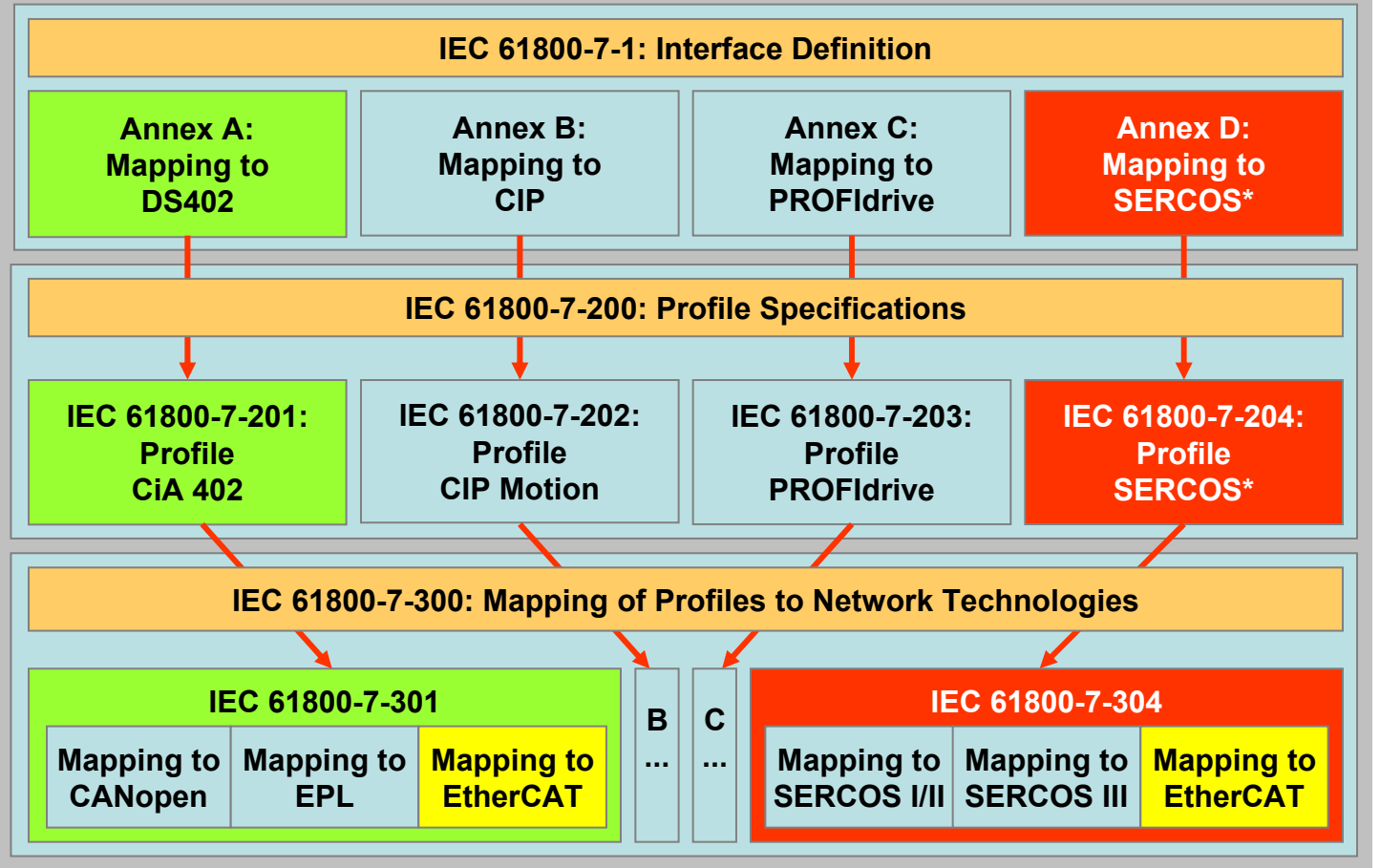

*SERCOS interface™ is a trademark by SI e.V.

EtherCAT is:

- Faster ✓
- Synchronization ✓
- Industrial Ethernet ✓
- Flexible ✓
- Easier to configure ✓
- Cost effective ✓
- Easier to implement ✓
- Well proven ✓
- Open
- Conformance
- Safety
- Redundancy
- Versatile



- Foundation: November 2003
- Tasks: Support, Advancement and Promotion of EtherCAT
- The worlds largest organization dedicated to Industrial Ethernet
- more than 940* member companies from 45 countries in 6 continents:
 - Device Manufacturers
 - End Users
 - Technology Providers
- Membership is open to everybody

EtherCAT is an open technology

EtherCAT is:

- Faster ✓
- Synchronization ✓
- Industrial Ethernet ✓
- Flexible ✓
- Easier to configure ✓
- Cost effective ✓
- Easier to implement ✓
- Well proven ✓
- Open
- Conformance
- Safety
- Redundancy
- Versatile

- Protocol is disclosed completely:
 - EtherCAT is IEC, ISO and SEMI Standard (IEC 61158, IEC 61784, ISO 15745, SEMI E54.20)



Commission Electrotechnique Internationale
International Electrotechnical Commission
Международная Электротехническая Комиссия



- Slave Controller from several sources available
- Slave Controller provides interoperability
- ETG organizes Interoperability Testing („Plug Fests“), Workshops and Seminars
- Conformance Testing + Certificates

EtherCAT is an open technology

EtherCAT is:

- Faster ✓
- Synchronization ✓
- Industrial Ethernet ✓
- Flexible ✓
- Easier to configure ✓
- Cost effective ✓
- Easier to implement ✓
- Well proven ✓
- Open
- Conformance
- Safety
- Redundancy
- Versatile

- Master Stacks for various RTOS available*, including Open / Shared Source!

- eCos
- Intime
- Linux with RT-Preempt
- On Time RTOS-32
- PikeOS
- Proconos OS
- Real-Time Java
- RMOS
- RT Kernel
- RT-Linux
- RTXQ Quadros
- RTAI Linux
- QNX
- VxWin + CeWin
- VxWorks
- Windows CE
- Windows XP/XPE with CoDeSys SP RTE
- Windows XP/XPE with TwinCAT RT-Extension
- XENOMAI Linux



*as of Feb 2009

EtherCAT is:

- Faster ✓
- Synchronization ✓
- Industrial Ethernet ✓
- Flexible ✓
- Easier to configure ✓
- Cost effective ✓
- Easier to implement ✓
- Well proven ✓
- Open
- Conformance
- Safety
- Redundancy
- Versatile

- Management Board of IEC has approved Liaison of EtherCAT Technology Group with IEC SC65C WG 11/12/13 + JWG10 (SC65C: Digital Communication)



Commission Electrotechnique Internationale
International Electrotechnical Commission
Международная Электротехническая Комиссия

- Thus ETG is official IEC Standardization Partner

EtherCAT is:

- Faster ✓
- Synchronization ✓
- Industrial Ethernet ✓
- Flexible ✓
- Easier to configure ✓
- Cost effective ✓
- Easier to implement ✓
- Well proven ✓
- Open
- Conformance
- Safety
- Redundancy
- Versatile



EtherCAT is:

- Faster ✓
- Synchronization ✓
- Industrial Ethernet ✓
- Flexible ✓
- Easier to configure ✓
- Cost effective ✓
- Easier to implement ✓
- Well proven ✓
- Open
- Conformance
- Safety
- Redundancy
- Versatile

- As of Feb 2009: 940 Members

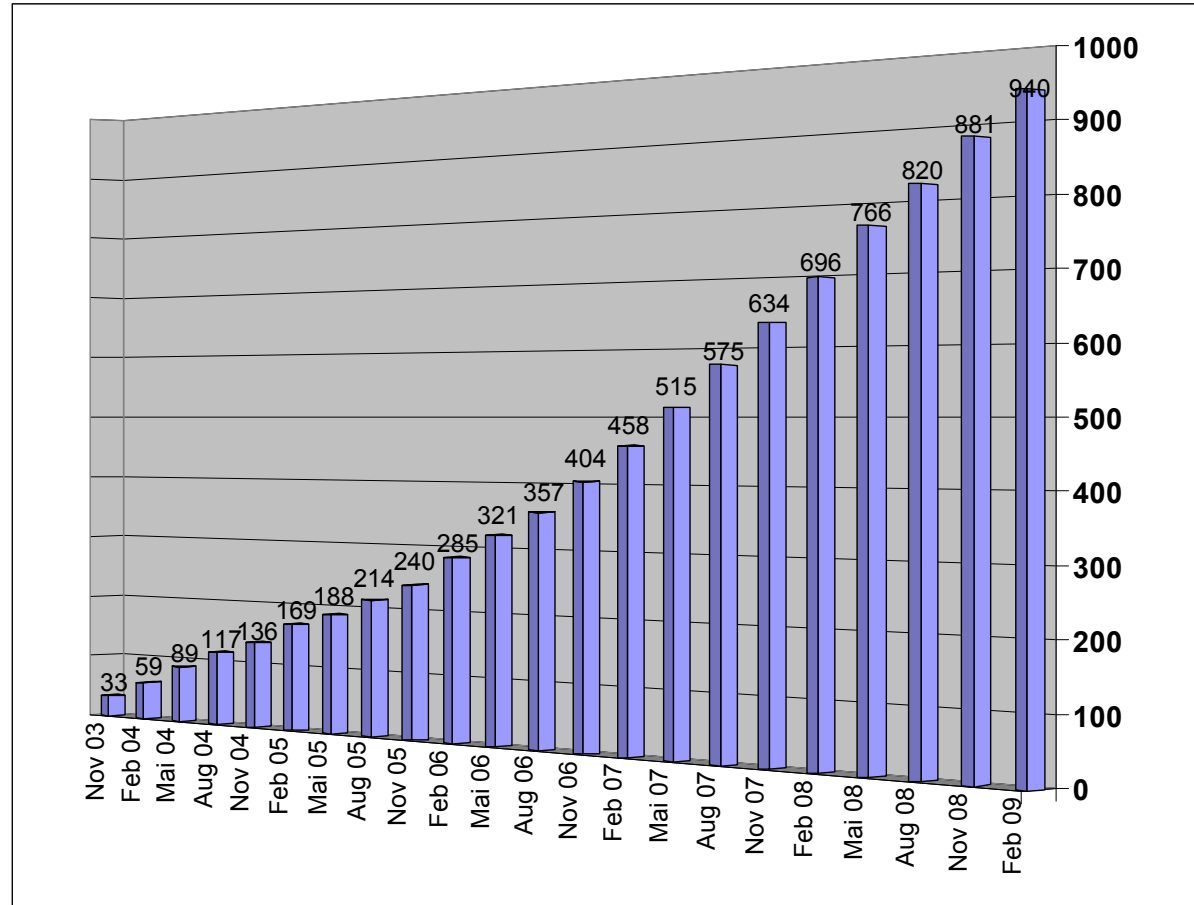

Members from 45* Countries, 6 Continents

EtherCAT is:

- Faster ✓
- Synchronization ✓
- Industrial Ethernet ✓
- Flexible ✓
- Easier to configure ✓
- Cost effective ✓
- Easier to implement ✓
- Well proven ✓
- Open
- Conformance
- Safety
- Redundancy
- Versatile

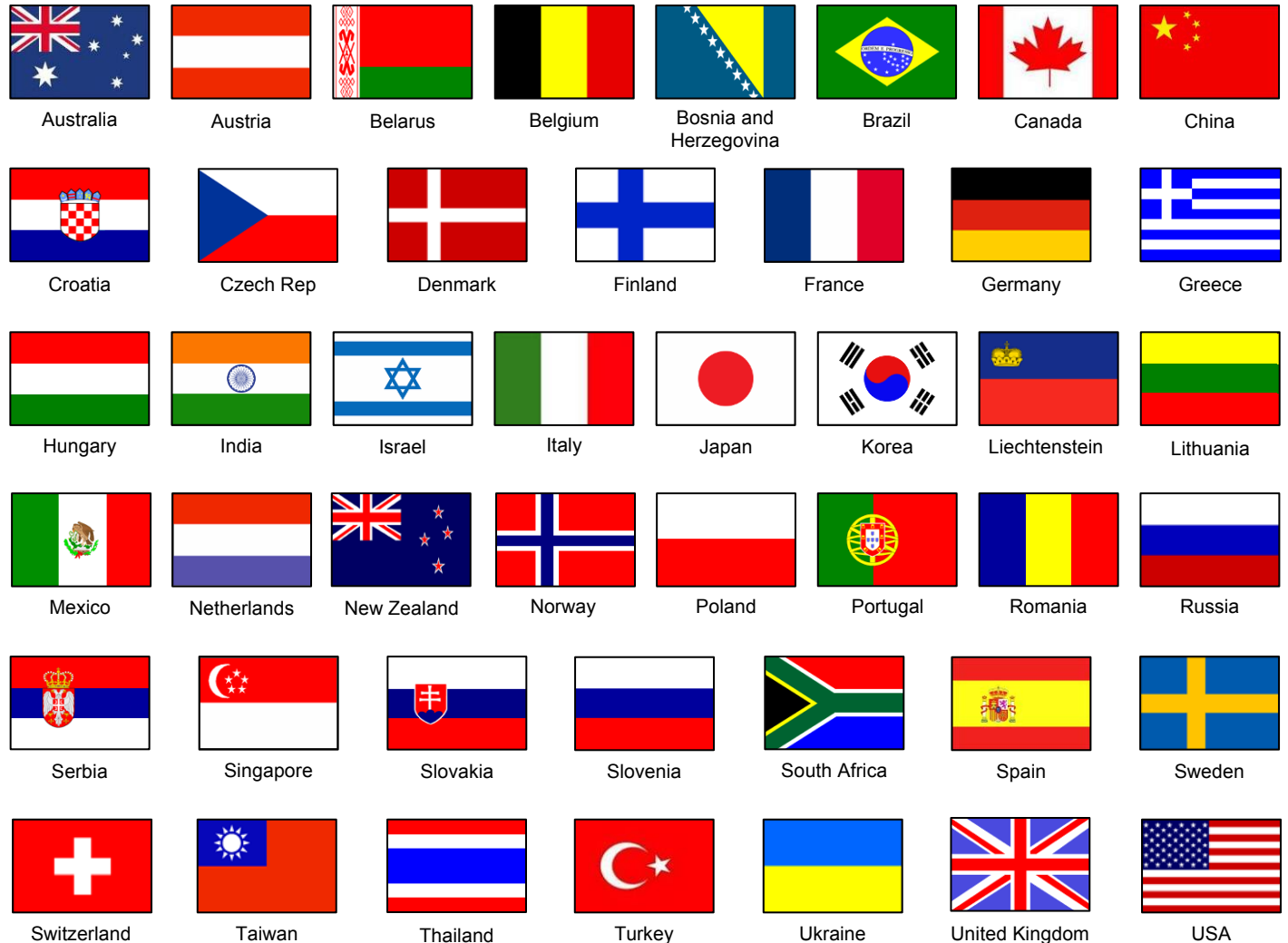

*as of Feb 2009

EtherCAT is:

- Faster ✓
- Synchronization ✓
- Industrial Ethernet ✓
- Flexible ✓
- Easier to configure ✓
- Cost effective ✓
- Easier to implement ✓
- Well proven ✓
- Open
- Conformance
- Safety
- Redundancy
- Versatile



ETG: Active Members

EtherCAT is:

- Faster ✓
- Synchronization ✓
- Industrial Ethernet ✓
- Flexible ✓
- Easier to configure ✓
- Cost effective ✓
- Easier to implement ✓
- Well proven ✓
- Open
- Conformance
- Safety
- Redundancy
- Versatile

- Much more important than membership figures: How many are active, how many implement the technology?
- Dec 2008: More than **690 Implementation Kits** sold to ETG Members (25% Master, 75% Slaves), plus there are Open + Shared Source masters!
- SPS/IPC/Drives 2008: 60 Vendors with over 180 different EtherCAT Devices at ETG booth:
 - 25 different drives from 16 manufacturers jointly operating in one network
 - 15 different functional Masters in one setup, using 10 different operating systems
 - Safety devices (master + slave devices) from 2 manufacturers operating in one system
 - Master to Master and redundancy live demo



EtherCAT: Large Product Selection

EtherCAT is:

- Faster ✓
- Synchronization ✓
- Industrial Ethernet ✓
- Flexible ✓
- Easier to configure ✓
- Cost effective ✓
- Easier to implement ✓
- Well proven ✓
- Open
- Conformance
- Safety
- Redundancy
- Versatile

I/O, Controller, HMI, Servo Drives, Variable Speed Drives
Sensors, Slave + Master Development Kits
Control Panels, Hydraulic Valves
and Pneumatic Valves,
...



EtherCAT is:

- Faster ✓
- Synchronization ✓
- Industrial Ethernet ✓
- Flexible ✓
- Easier to configure ✓
- Cost effective ✓
- Easier to implement ✓
- Well proven ✓
- Open ✓
- Conformance
- Safety
- Redundancy
- Versatile



- Conformance and interoperability are very important factors for the success of a communication technology
 - Conformity to the specification is an obligation to all users of the EtherCAT technology
 - Therefore the **EtherCAT Conformance Test Tool (CTT)** is used
 - Test Cases for the CTT are provided by the Working Group „Conformance“ within the ETG community
 - The **EtherCAT Conformance Test** proves conformance officially with issuing a certificate after passing the test at an official **EtherCAT Test Center (ETC)**

EtherCAT is:

- Faster ✓
- Synchronization ✓
- Industrial Ethernet ✓
- Flexible ✓
- Easier to configure ✓
- Cost effective ✓
- Easier to implement ✓
- Well proven ✓
- Open ✓
- Conformance ✓
- Safety
- Redundancy
- Versatile

Safety over EtherCAT®



- Safety over EtherCAT (FSoE) defines a safety communication layer for the transportation of safety process data between Safety over EtherCAT devices.
- FSoE is an open technology within the EtherCAT Technology Group (ETG).
- The protocol is developed according to IEC 61508
 - It meets the Safety Integrity Level (SIL) 3
 - Residual Error Probability $R(p) < 10^{-9}$
- The protocol is approved by an independent Notified Body (TÜV)

EtherCAT is:

- Faster ✓
- Synchronization ✓
- Industrial Ethernet ✓
- Flexible ✓
- Easier to configure ✓
- Cost effective ✓
- Easier to implement ✓
- Well proven ✓
- Open ✓
- Conformance ✓
- Safety
- Redundancy
- Versatile

Safety over EtherCAT®

- FSoE Frame is mapped in the cyclic PDOs
 - Minimum FSoE Frame-Length: 6 Byte
 - Maximum FSoE Frame-Length: depending on the number of safe process data of the Slave Device
 - Therefore the protocol is suitable for safe I/O as well as for functional safe motion control
- Confirmed transfer from the FSoE Master to the FSoE Slave and vice versa.
- Safe Device Parameter can be downloaded from the Master to the Slave at Boot-Up of a FSoE Connection
- Certified products with Safety over EtherCAT are available since 2005.

EtherCAT is:

- Faster ✓
- Synchronization ✓
- Industrial Ethernet ✓
- Flexible ✓
- Easier to configure ✓
- Cost effective ✓
- Easier to implement ✓
- Well proven ✓
- Open ✓
- Conformance ✓
- Safety
- Redundancy
- Versatile

Safety over EtherCAT®

- The FSoE specification has no restrictions according to:
 - Communication layer and interface
The communication layer is not part of the safety measures:
black channel
(assumed unsolved bit error rate: $p = 10^{-2}$)
 - Transmission speed
 - Length of safe process data
(length of safe process data is arbitrary)
- Routing via unsafe gateways, fieldbus systems or backbones is possible

EtherCAT is:

- Faster ✓
- Synchronization ✓
- Industrial Ethernet ✓
- Flexible ✓
- Easier to configure ✓
- Cost effective ✓
- Easier to implement ✓
- Well proven ✓
- Open ✓
- Conformance ✓
- Safety
- Redundancy
- Versatile

Safety over **EtherCAT**

- Can be routed via non-safe gateways
- Can be routed via fieldbus systems
- One Safety technology for (almost) all bus systems



EtherCAT is:

- Faster ✓
- Synchronization ✓
- Industrial Ethernet ✓
- Flexible ✓
- Easier to configure ✓
- Cost effective ✓
- Easier to implement ✓
- Well proven ✓
- Open ✓
- Conformance ✓
- Safety
- Redundancy
- Versatile

- Black channel approach
 - with safety and non-safety data on the same bus

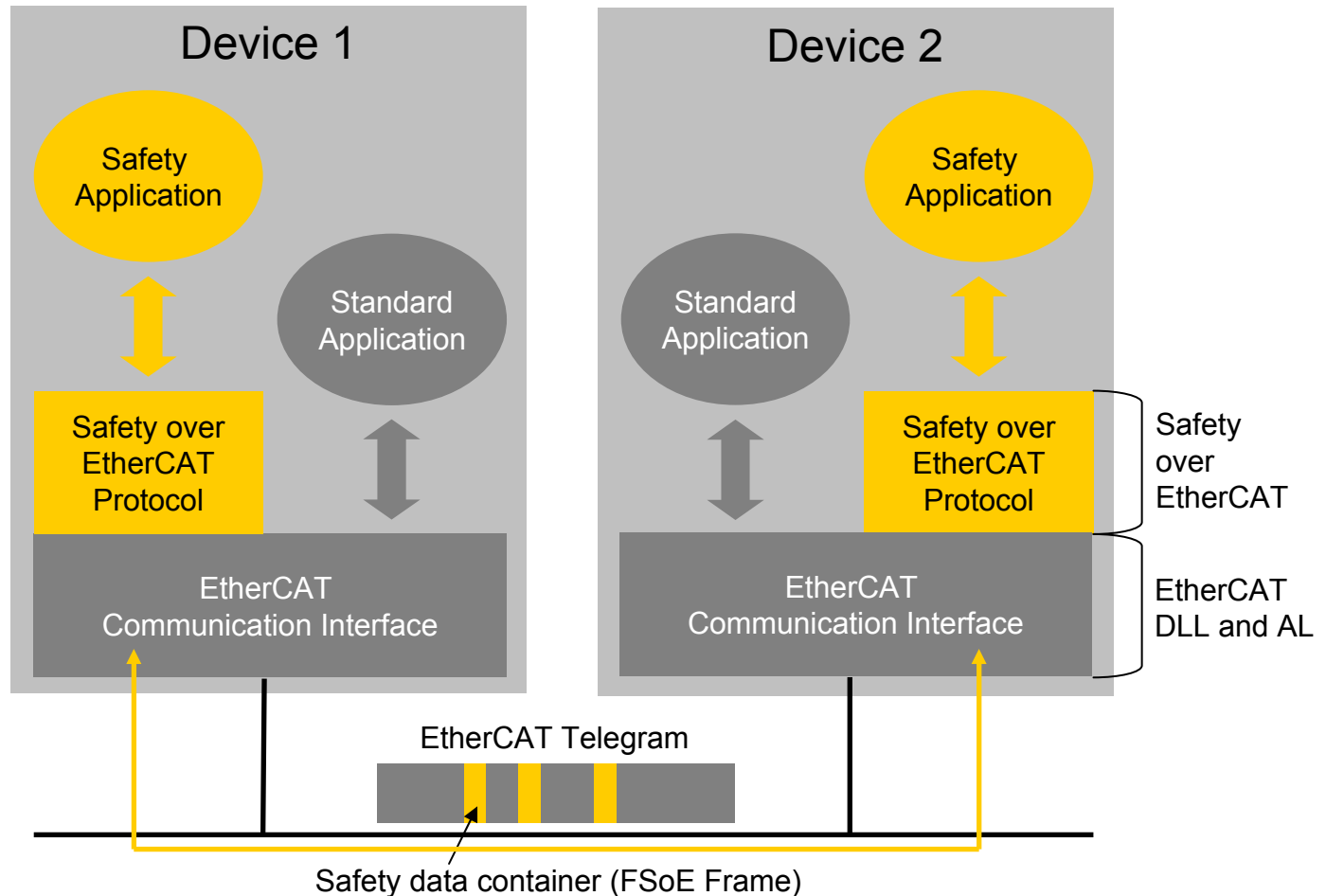

EtherCAT is:

- Faster ✓
- Synchronization ✓
- Industrial Ethernet ✓
- Flexible ✓
- Easier to configure ✓
- Cost effective ✓
- Easier to implement ✓
- Well proven ✓
- Open ✓
- Conformance ✓
- Safety
- Redundancy
- Versatile

- One channel communication system
 - Model A according to IEC 61784-3 Annex A

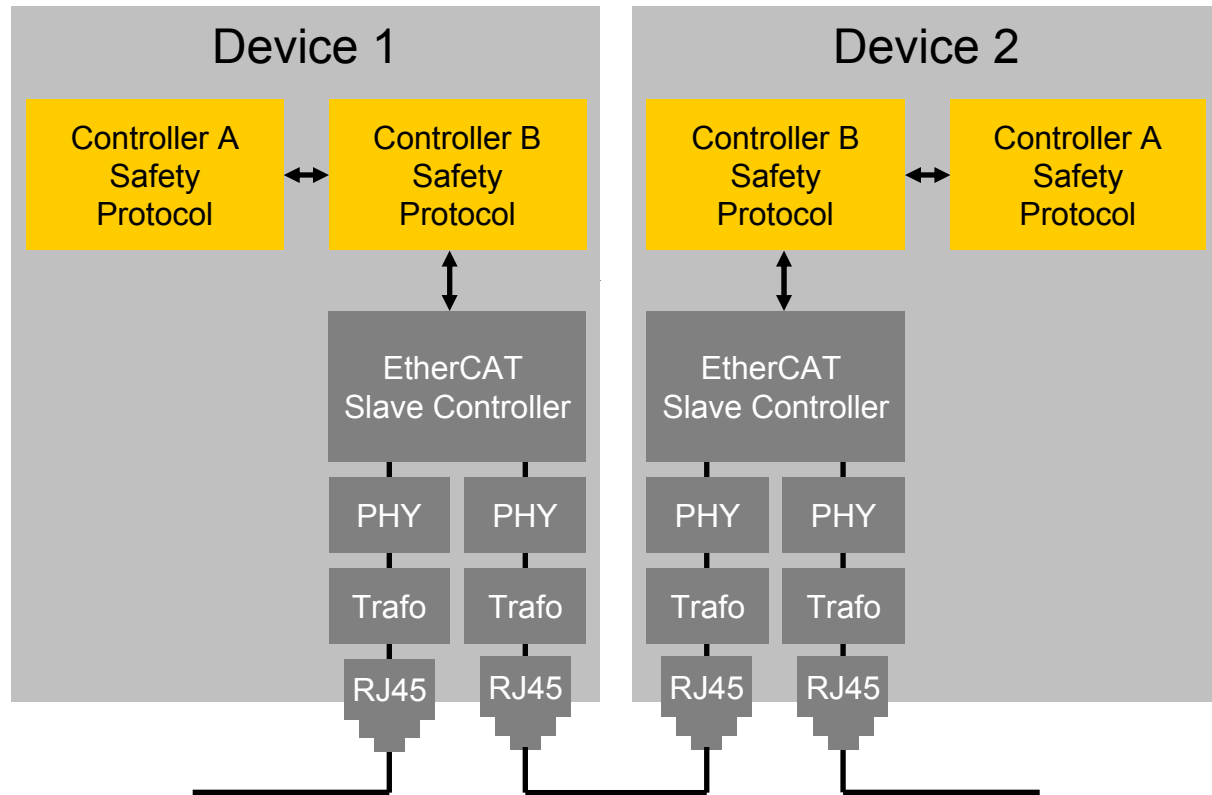

EtherCAT is:

- Faster ✓
- Synchronization ✓
- Industrial Ethernet ✓
- Flexible ✓
- Easier to configure ✓
- Cost effective ✓
- Easier to implement ✓
- Well proven ✓
- Open ✓
- Conformance ✓
- Safety
- Redundancy
- Versatile

- Ethernet telegram

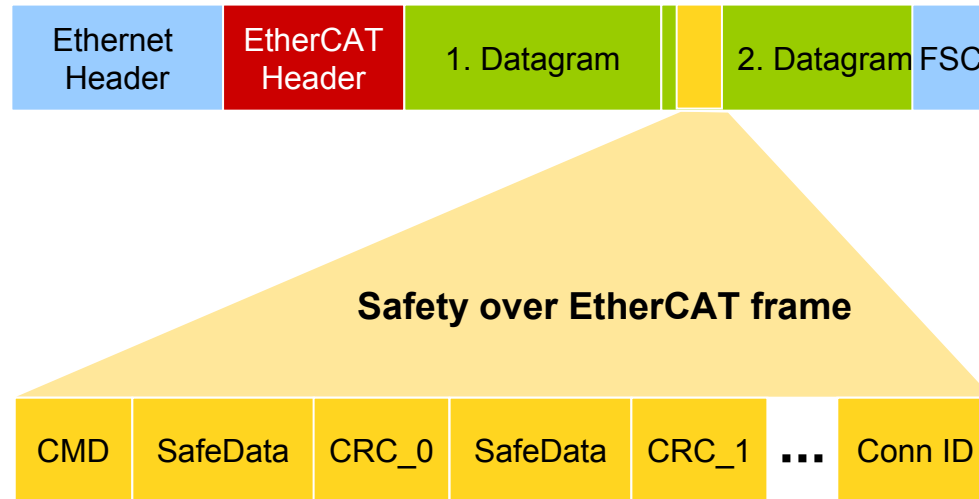

- Safety over EtherCAT frame

- The FSoE Frame is a data container mapped in the process data of the devices
- A new FSoE Frame is recognized if at least one bit has changed according to the last frame
- For every 2 Byte SafeData a 2 Byte CRC is calculated
- Up to n Byte SafeData can be transmitted

EtherCAT is:

- Faster ✓
- Synchronization ✓
- Industrial Ethernet ✓
- Flexible ✓
- Easier to configure ✓
- Cost effective ✓
- Easier to implement ✓
- Well proven ✓
- Open ✓
- Conformance ✓
- Safety
- Redundancy
- Versatile

Measure	Sequence Number	Watchdog	Connection ID	CRC Calculation
Error				
Unintended repetition	☑			☑
Loss	☑	☑		☑
Insertion	☑			☑
Incorrect sequence	☑			☑
Corruption				☑
Unacceptable delay		☑		
Masquerade		☑		☑
Repeating memory errors in Switches	☑			☑
Incorrect forwarding between segments			☑	

EtherCAT is:

- Faster ✓
- Synchronization ✓
- Industrial Ethernet ✓
- Flexible ✓
- Easier to configure ✓
- Cost effective ✓
- Easier to implement ✓
- Well proven ✓
- Open ✓
- Conformance ✓
- Safety
- Redundancy
- Versatile

- Decentralized Safety-Logic
- Standard PLC routes the safety messages

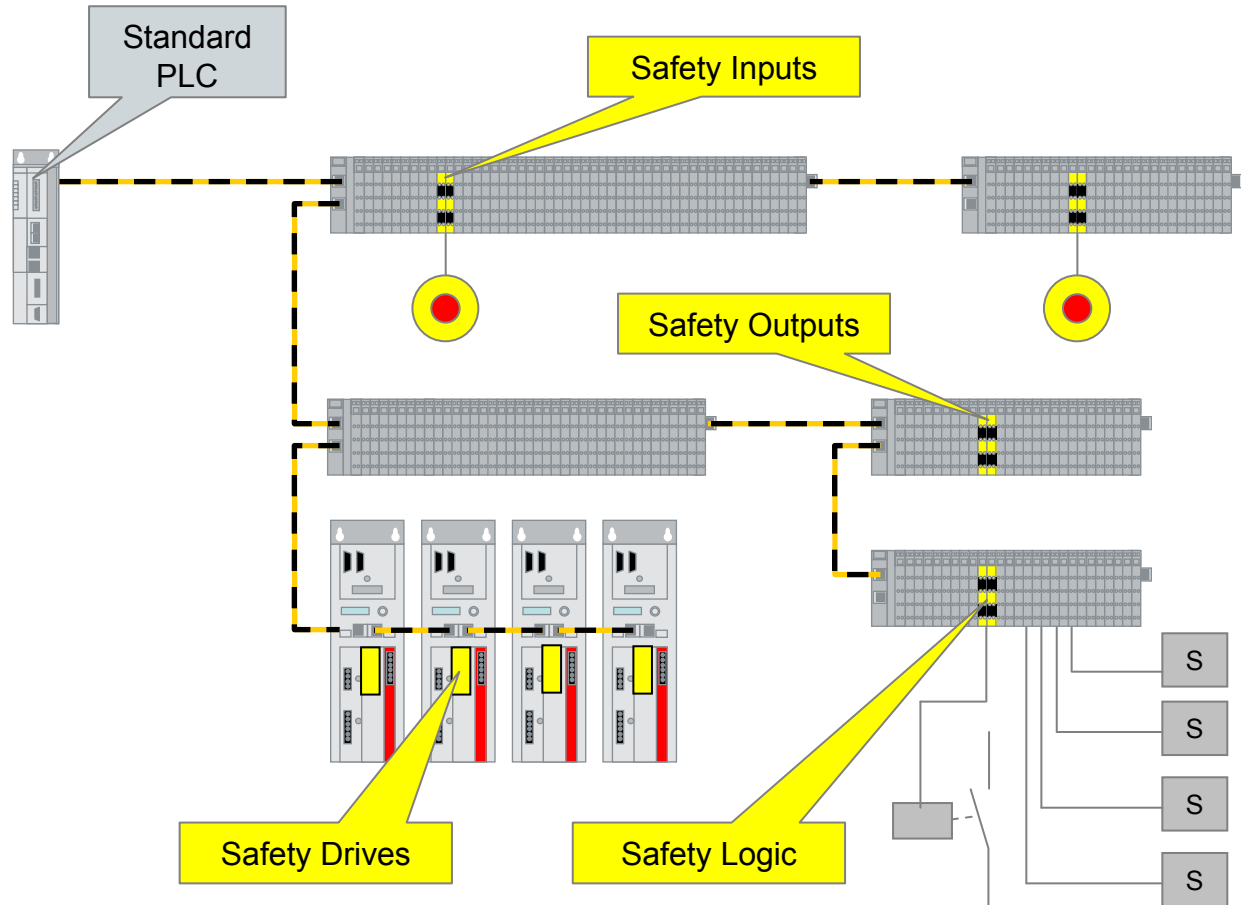

EtherCAT is:

- Faster ✓
- Synchronization ✓
- Industrial Ethernet ✓
- Flexible ✓
- Easier to configure ✓
- Cost effective ✓
- Easier to implement ✓
- Well proven ✓
- Open ✓
- Conformance ✓
- Safety
- Redundancy
- Versatile

- Fully integrated solution:
 - safe and standard communication in one channel
- Reduction of fieldbuses and interfaces
- Central configuration, diagnosis and maintenance for safe and ,unsafe‘ I/O in one tool
- Safety application makes full use of EtherCAT advantages:
 - Short reaction times
 - Almost unlimited number of nodes
 - Large network extensions
 - Cable redundancy options
 - High Flexibility with Hot Connect

EtherCAT: High availability

EtherCAT is:

- Faster ✓
- Synchronization ✓
- Industrial Ethernet ✓
- Flexible ✓
- Easier to configure ✓
- Cost effective ✓
- Easier to implement ✓
- Well proven ✓
- Open ✓
- Conformance ✓
- Safety ✓
- Redundancy
- Versatile

- Cabling redundancy
 - 2nd Ethernet port needed on master side only
- Hot Swap of devices
- Hot Connect of network segments
- Master Redundancy with Hot Swap

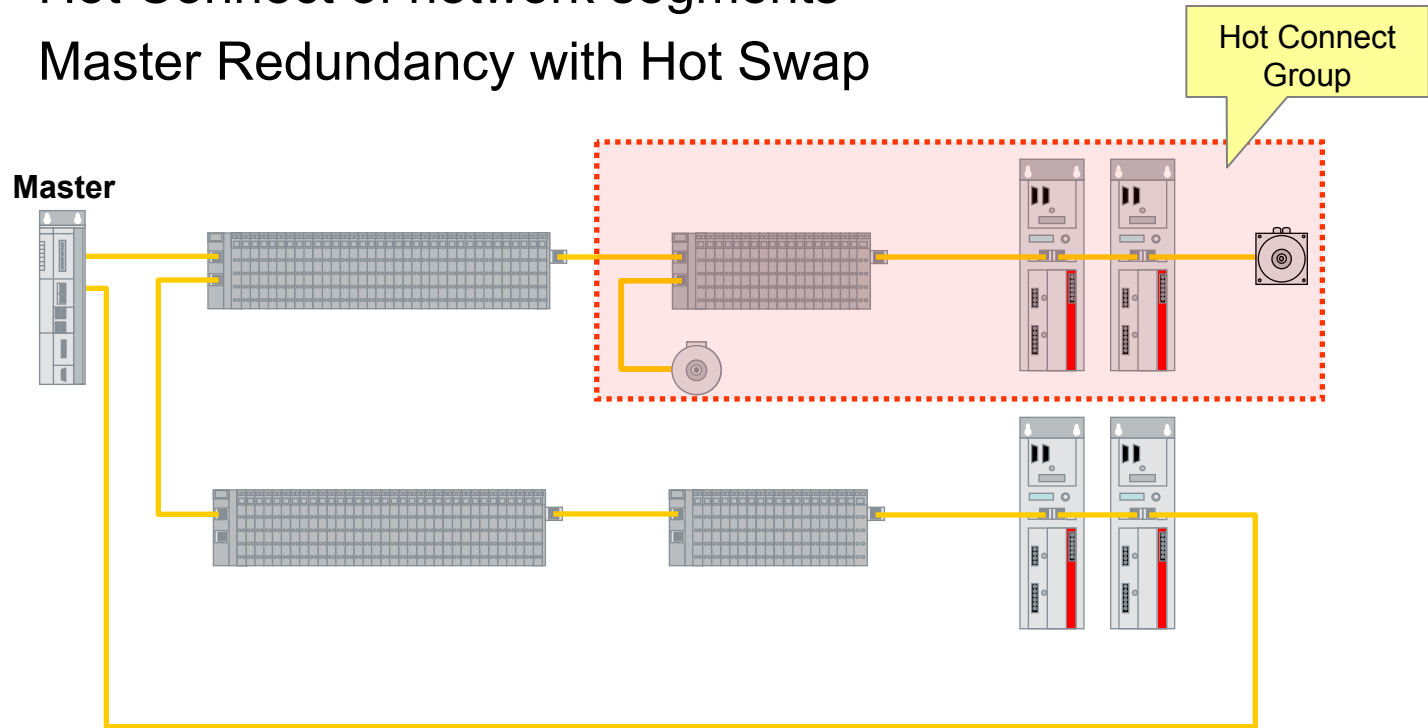

Without Redundancy: Normal Operation

EtherCAT is:

- Faster ✓
- Synchronization ✓
- Industrial Ethernet ✓
- Flexible ✓
- Easier to configure ✓
- Cost effective ✓
- Easier to implement ✓
- Well proven ✓
- Open ✓
- Conformance ✓
- Safety ✓
- Redundancy
- Versatile

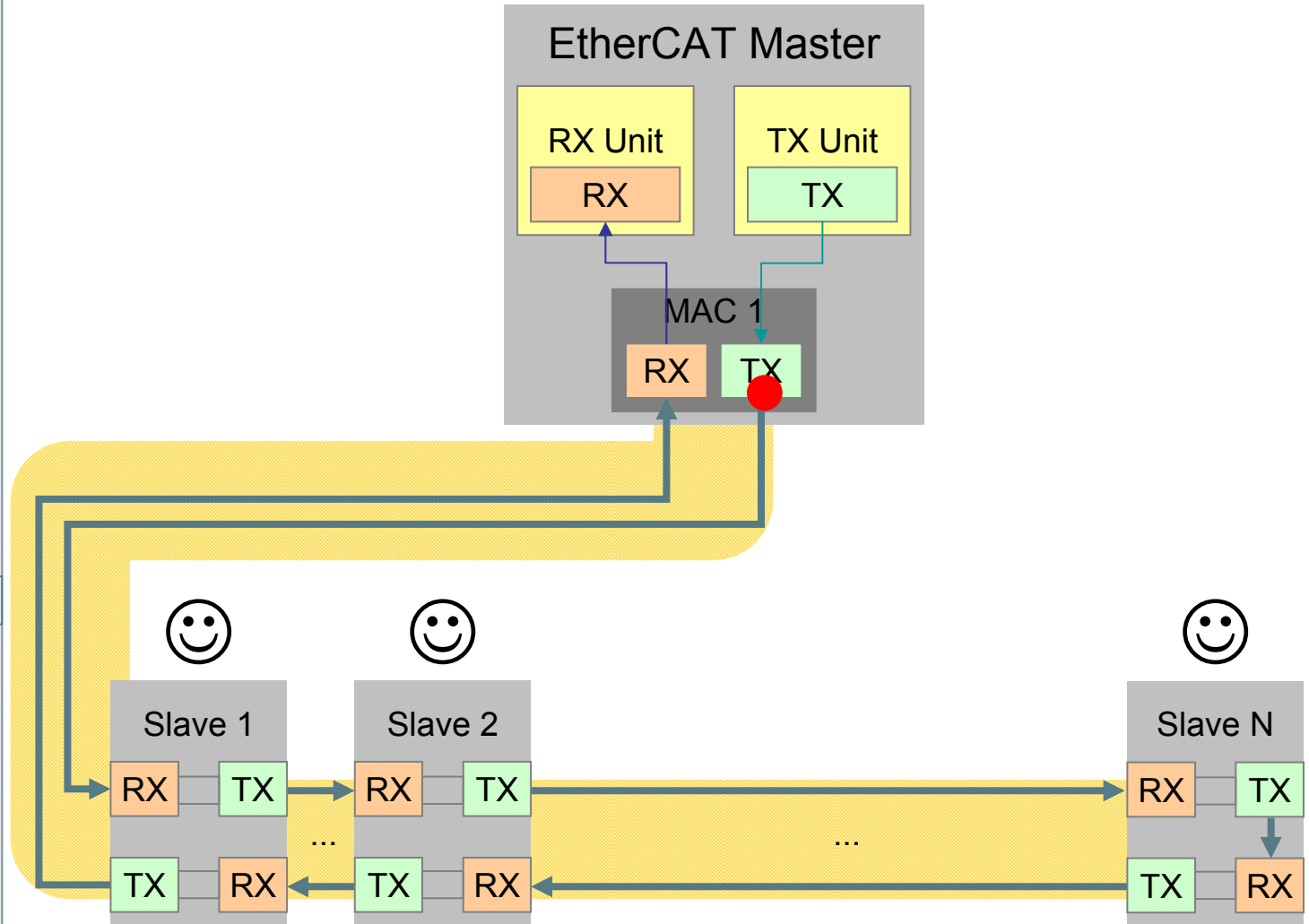

Without Redundancy: Node or Cable Failure

EtherCAT is:

- Faster ✓
- Synchronization ✓
- Industrial Ethernet ✓
- Flexible ✓
- Easier to configure ✓
- Cost effective ✓
- Easier to implement ✓
- Well proven ✓
- Open ✓
- Conformance ✓
- Safety ✓
- Redundancy
- Versatile

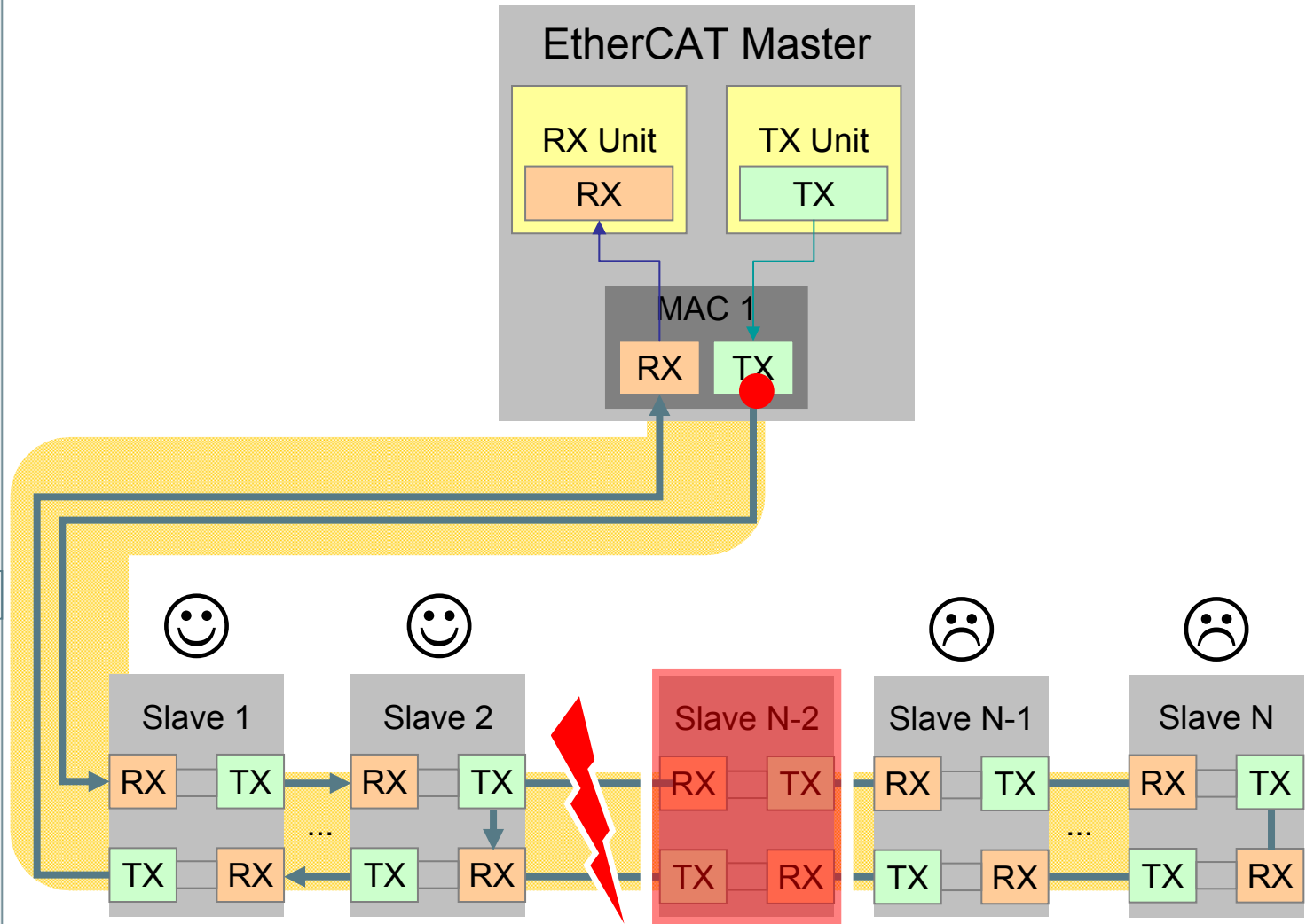

With Redundancy: Normal Operation

EtherCAT is:

- Faster ✓
- Synchronization ✓
- Industrial Ethernet ✓
- Flexible ✓
- Easier to configure ✓
- Cost effective ✓
- Easier to implement ✓
- Well proven ✓
- Open ✓
- Conformance ✓
- Safety ✓
- Redundancy
- Versatile

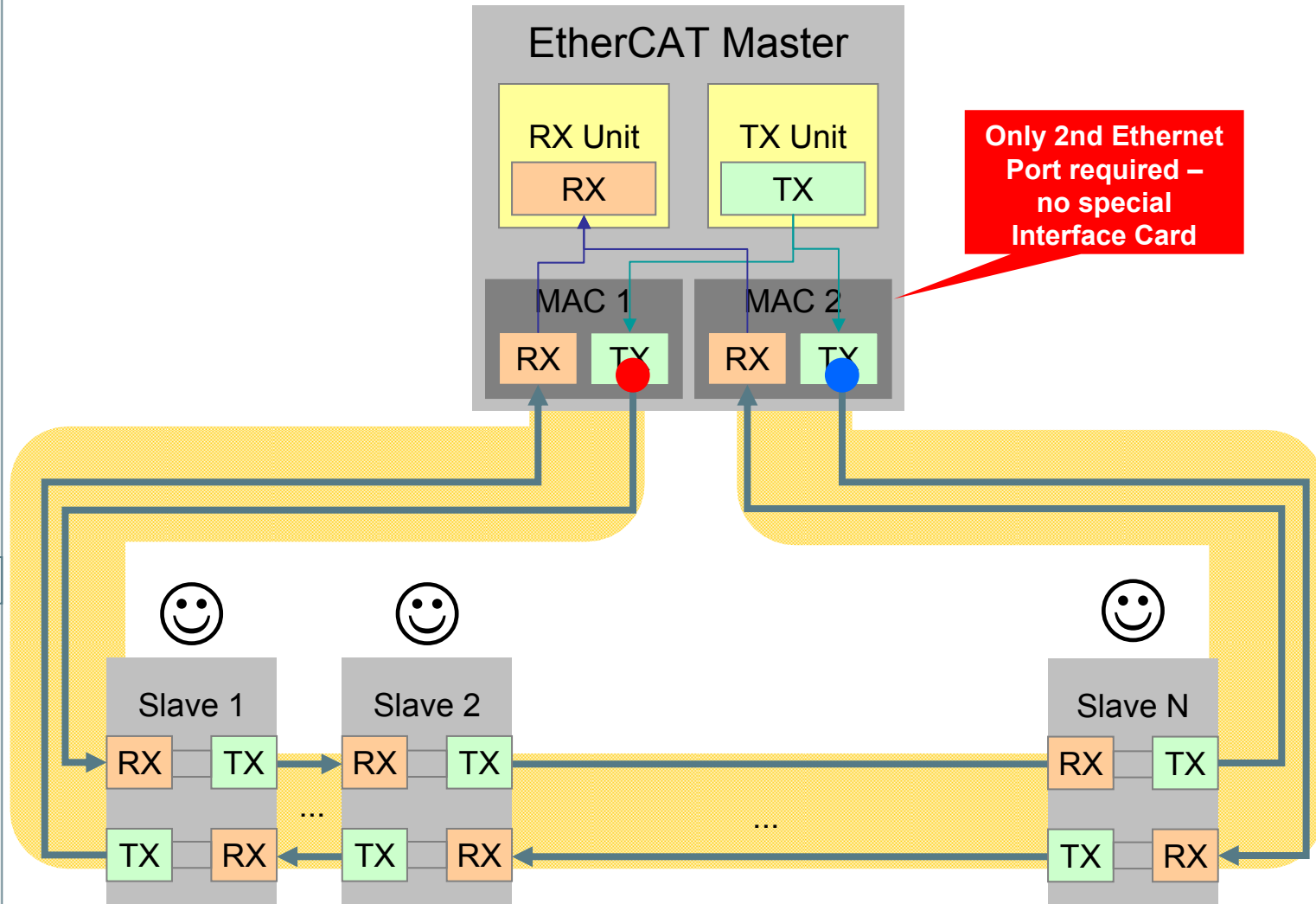

With Redundancy: Node or Cable Failure

EtherCAT is:

- Faster ✓
- Synchronization ✓
- Industrial Ethernet ✓
- Flexible ✓
- Easier to configure ✓
- Cost effective ✓
- Easier to implement ✓
- Well proven ✓
- Open ✓
- Conformance ✓
- Safety ✓
- Redundancy
- Versatile

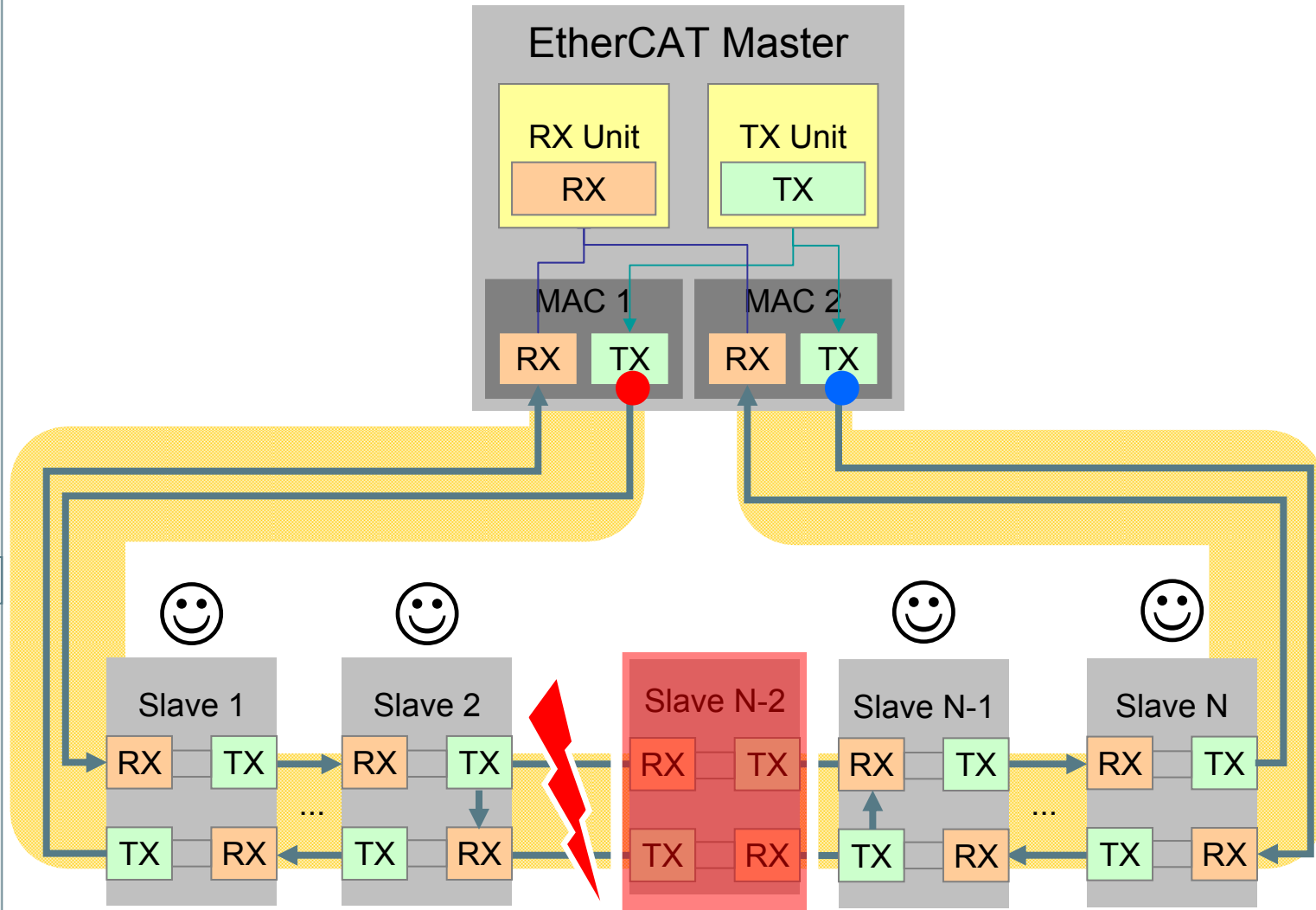

EtherCAT: various system architecture

EtherCAT is:

- Faster ✓
- Synchronization ✓
- Industrial Ethernet ✓
- Flexible ✓
- Easier to configure ✓
- Cost effective ✓
- Easier to implement ✓
- Well proven ✓
- Open ✓
- Conformance ✓
- Safety ✓
- Redundancy ✓
- Versatile

- Master to Slave
- Slave to Slave
- Master to Master

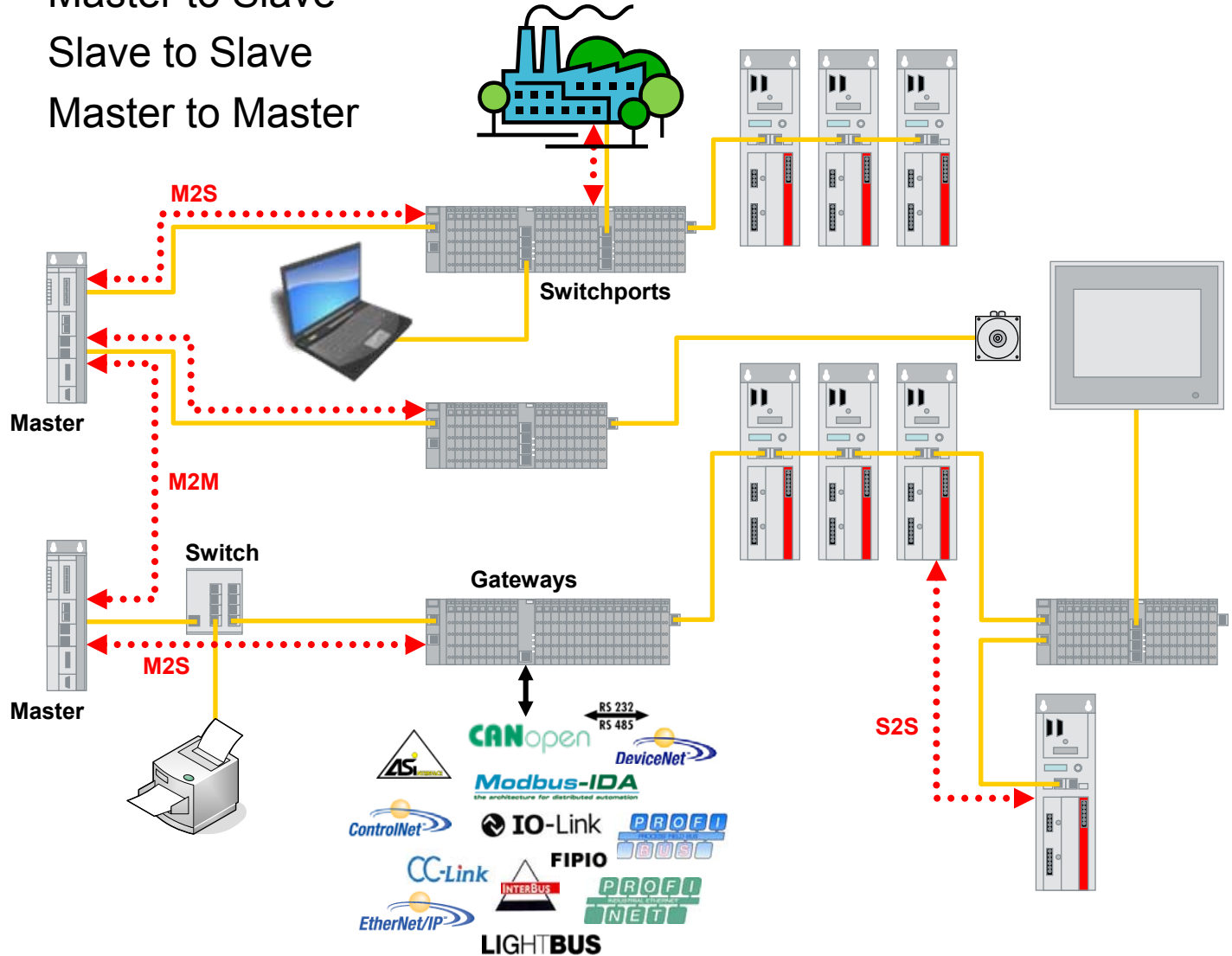

EtherCAT is:

- Faster ✓
- Synchronization ✓
- Industrial Ethernet ✓
- Flexible ✓
- Easier to configure ✓
- Cost effective ✓
- Easier to implement ✓
- Well proven ✓
- Open ✓
- Conformance ✓
- Safety ✓
- Redundancy ✓
- Versatile

- Wireless Devices can be connected via Switchport
- Wireless segment does not slow down EtherCAT communication
- Protocol: EtherCAT Automation Protocol
 - Pushed and/or Polled Process Data Exchange
- Wireless Segment transparent for Master Device

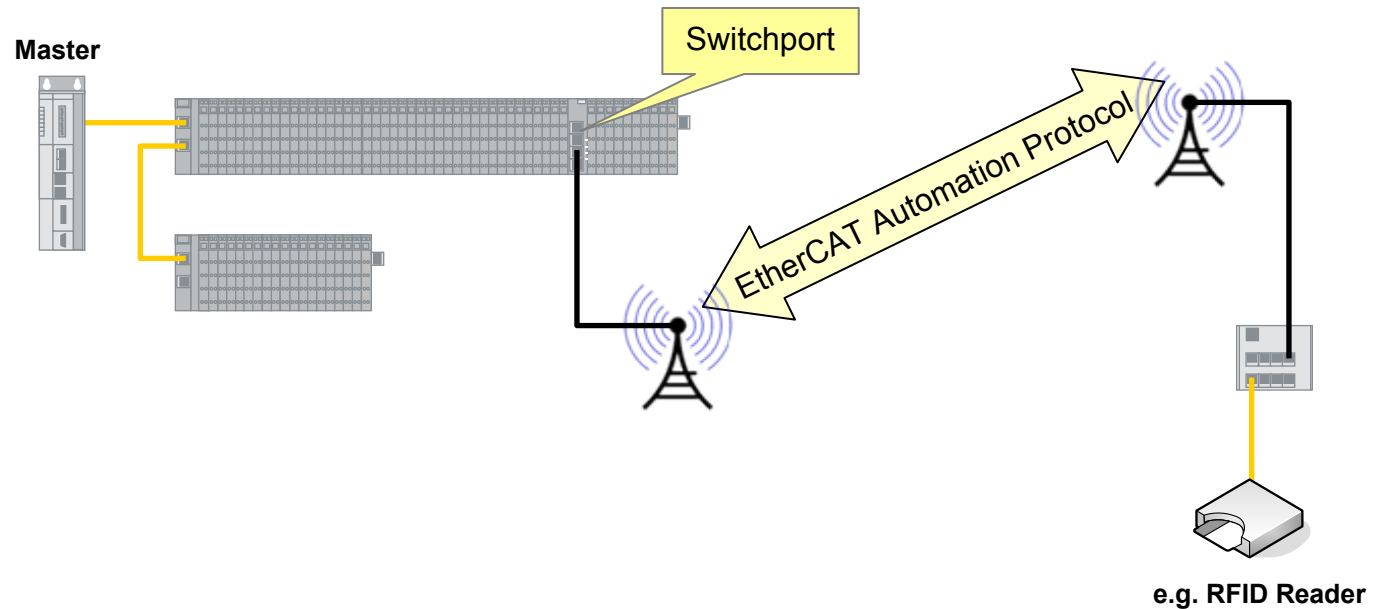

Why do Companies choose EtherCAT?

EtherCAT is:

- Faster ✓
- Synchronization ✓
- Industrial Ethernet ✓
- Flexible ✓
- Easier to configure ✓
- Cost effective ✓
- Easier to implement ✓
- Well proven ✓
- Open ✓
- Conformance ✓
- Safety ✓
- Redundancy ✓
- Versatile ✓

- **High Performance**
 - EtherCAT is the fastest Industrial Ethernet technology
- **Flexible Topology**
 - Benefit not only for widely distributed applications
- **Ease of Use**
 - Easy configuration and maintenance
- **Low Cost**
 - Inexpensive implementation & infrastructure
- **Functional Safety**
 - Safety communication integrated
- **Product Variety**
 - Great variety of available EtherCAT products

EtherCAT is:

- Faster ✓
- Synchronization ✓
- Industrial Ethernet ✓
- Flexible ✓
- Easier to configure ✓
- Cost effective ✓
- Easier to implement ✓
- Well proven ✓
- Open ✓
- Conformance ✓
- Safety ✓
- Redundancy ✓
- Versatile ✓

- Fast applications, e.g.:
 - packaging machines
 - high speed presses
 - injection molding machines
 - woodworking machines
 - machine tooling (CNC)
 - test beds
 - robotics
 - ...
- Widely distributed applications, e.g.:
 - materials handling
 - logistics
 - data acquisition
 - ...



EtherCAT is:

- Faster ✓
- Synchronization ✓
- Industrial Ethernet ✓
- Flexible ✓
- Easier to configure ✓
- Cost effective ✓
- Easier to implement ✓
- Well proven ✓
- Open ✓
- Conformance ✓
- Safety ✓
- Redundancy ✓
- Versatile

- Due to low cost master and simple wiring as well:
 - Small Embedded Controller
 - Small PLCs
 - Any PC based Control Application
 - with or without real time requirements
- EtherCAT allows one to apply fieldbus technology where cost issues require direct wiring today

EtherCAT is:

- Faster ✓
- Synchronization ✓
- Industrial Ethernet ✓
- Flexible ✓
- Easier to configure ✓
- Cost effective ✓
- Easier to implement ✓
- Well proven ✓
- Open ✓
- Conformance ✓
- Safety ✓
- Redundancy ✓
- Versatile ✓

Please visit
www.ethercat.org
for more information

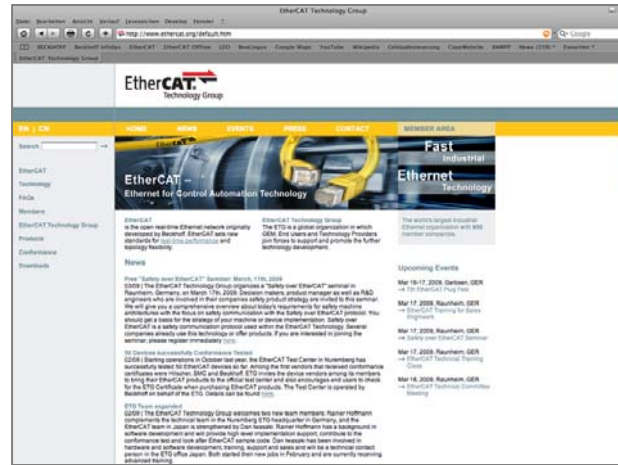

EtherCAT Technology Group
ETG Headquarters
Ostendstr. 196
90482 Nuremberg, Germany
Phone: +49 911 54056 20
info@ethercat.org