



EtherCAT is:

- faster
- Industrial Ethernet
- more flexible to wire
- easier to configure
- lower cost
- easier to implement
- well proven
- open
- safety
- redundancy
- versatile

EtherCAT Introduction

- Functional Principles
- Topology
- Benefits
- Application Fields
- Implementation

WELCOME

EtherCAT is the Ethernet Fieldbus

EtherCAT is:

- faster
- Industrial Ethernet
- more flexible to wire
- easier to configure
- lower cost
- easier to implement
- well proven
- open
- safety
- redundancy
- versatile

- **EtherCAT is realtime down to the I/O level**
- **no underlying sub-systems any more**
- **no delays in gateways**
- **In- and outputs, sensors, drives, displays: everything on one system!**

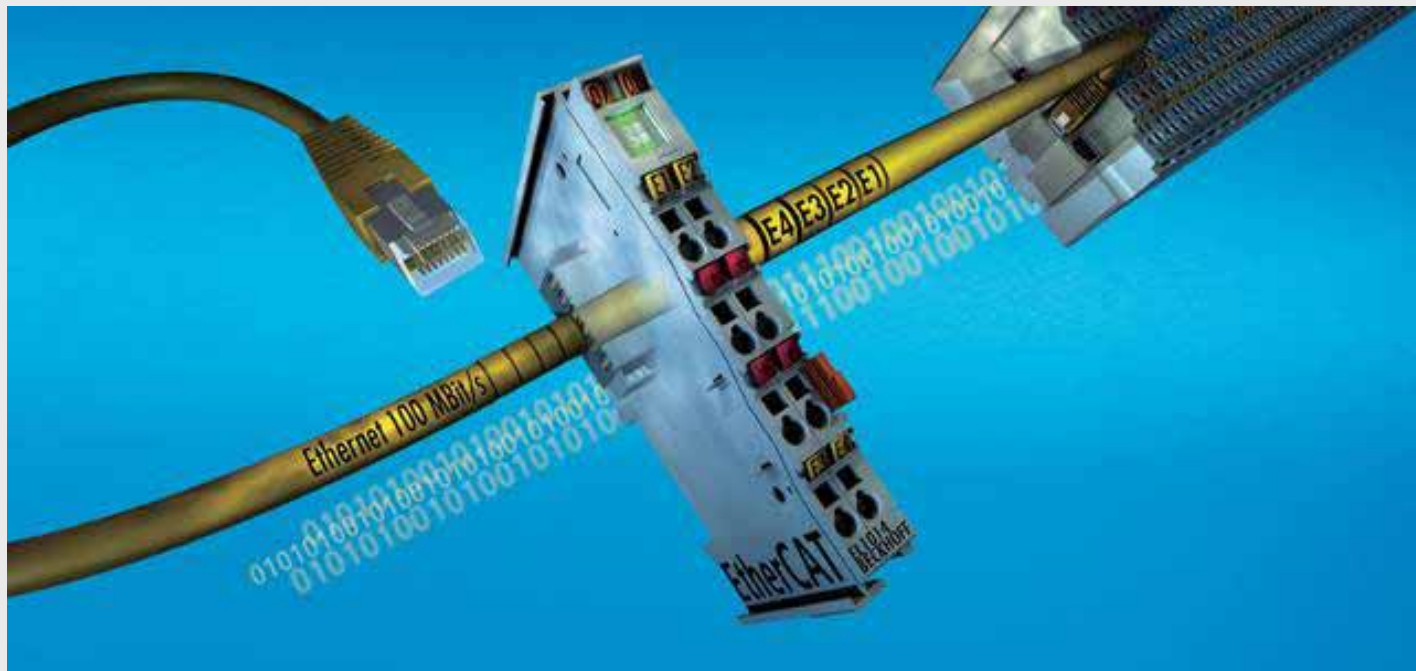



EtherCAT is:

- faster
- Industrial Ethernet
- more flexible to wire
- easier to configure
- lower cost
- easier to implement
- well proven
- open
- safety
- redundancy
- versatile

Transmission Rate: 2 x 100 Mbaud (Full-Duplex)

Update Times:

- 256 digital I/O in 11 μ s
- **1000 digital I/O** distributed to 100 nodes **in 30 μ s** = 0.03 ms
- 200 analog I/O (16 bit) in 50 μ s, 20 kHz Sampling Rate
- **100 Servo-Axis** (each 8 Byte IN+OUT) **in 100 μ s** = 0.1 ms
- 12000 digital I/O in 350 μ s

EtherCAT is faster

EtherCAT is:

- faster
- Industrial Ethernet
- more flexible to wire
- easier to configure
- lower cost
- easier to implement
- well proven
- open
- safety
- redundancy
- versatile

Bandwidth Usage of Ethernet for I/O and Drives:

Ethernet Frame: ≥ 84 Bytes
(incl. Preamble + IPG Inter-Packet Gap)

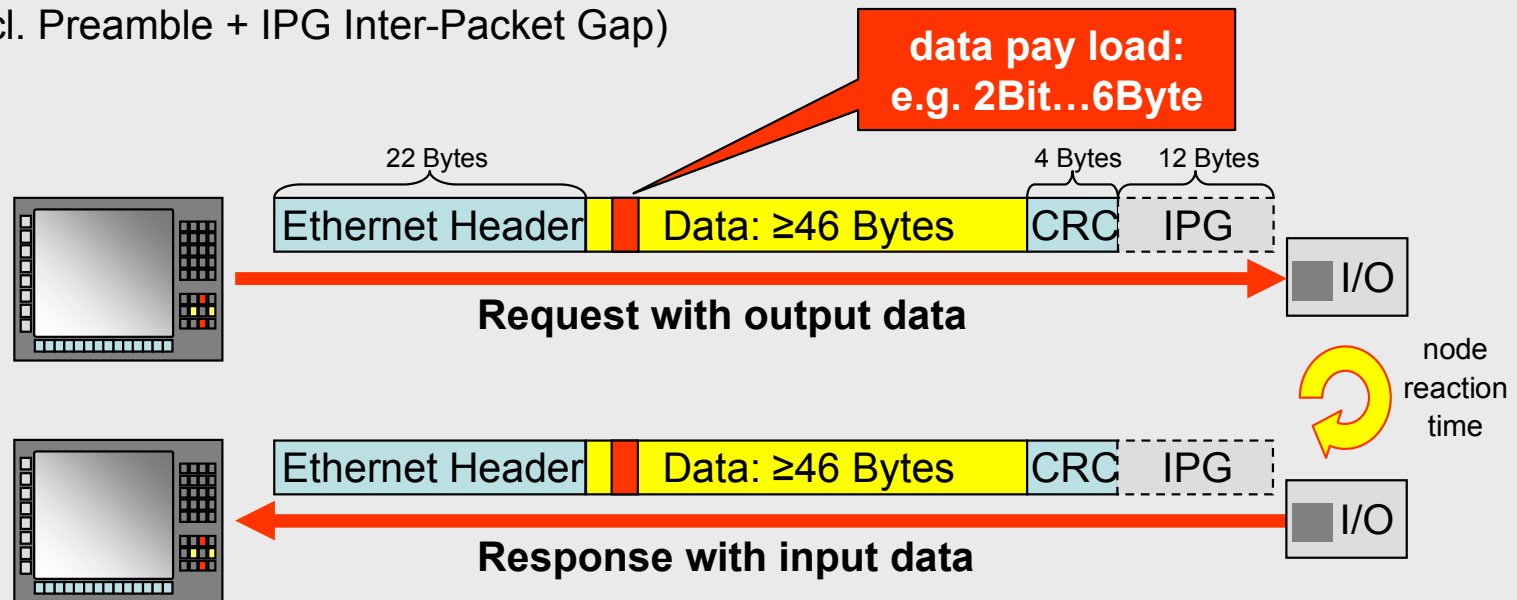

with 4 Byte input + 4 Byte output per node:

4,75% application data ratio at $0\mu\text{s}$ reaction time/node

1,9% application data ratio at $10\mu\text{s}$ reaction time/node

EtherCAT is faster

EtherCAT is:

- faster
- Industrial Ethernet
- more flexible to wire
- easier to configure
- lower cost
- easier to implement
- well proven
- open
- safety
- redundancy
- versatile

Bandwidth Usage Comparison:

At 4 Byte user data per node:

- Polling / Timeslicing: ca. 2..5%
- Broadcast (Master → Slaves): ca. 20...30%

From 2 Bit user data per node:

- **EtherCAT: 80...97%**

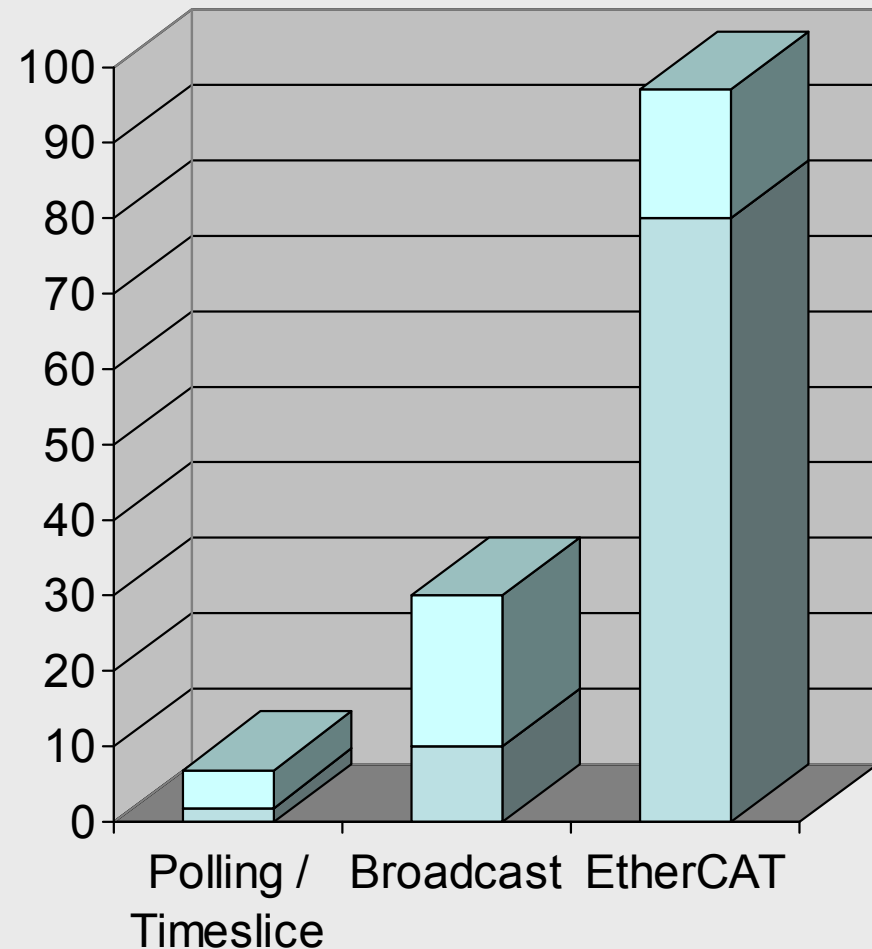

Functional Principle: Ethernet “on the Fly”

EtherCAT is:

- faster
- Industrial Ethernet
- more flexible to wire
- easier to configure
- lower cost
- easier to implement
- well proven
- open
- safety
- redundancy
- versatile

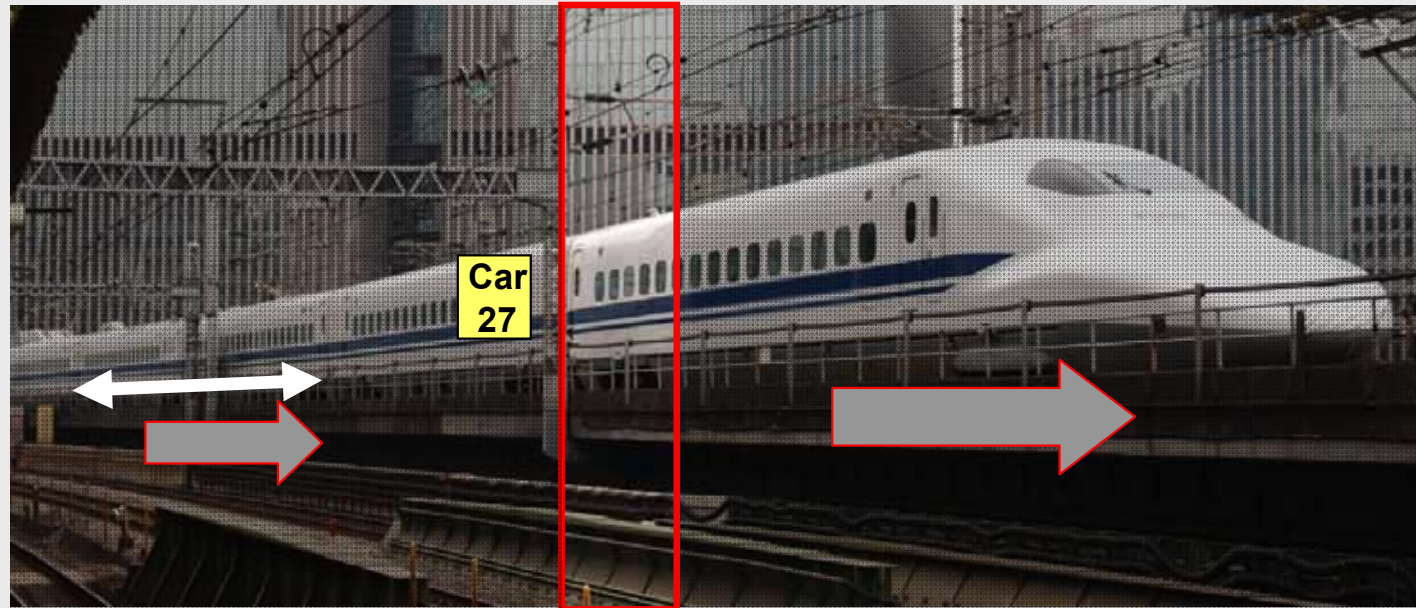

Analogy Fast Train:

- “Train” (Ethernet Frame) does not stop
- Even when watching “train” through narrow window one sees the entire train
- “Car” (Sub-Telegram) has variable length
- One can “extract” or “insert” single “persons” (Bits) or entire “groups” – even multiple groups per train

Functional Principle: Ethernet “on the Fly”

EtherCAT is:

- faster
- Industrial Ethernet
- to wire
- easier to configure
- lower cost
- easier to implement
- well proven
- open
- safety
- redundancy
- versatile

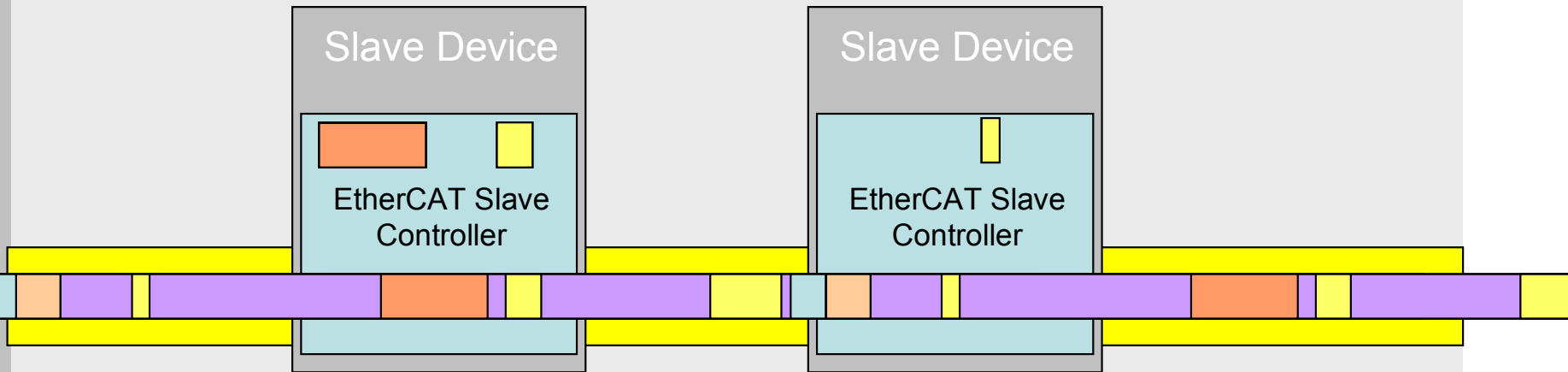

Process data is extracted and inserted on the fly

- Process data size per slave almost unlimited (1 Bit...60 Kbyte, if needed using several frames)
- Compilation of process data can change in each cycle, e.g. ultra short cycle time for axis, and longer cycles for I/O update possible
- In addition asynchronous, event triggered communication

Functional Principle: Ethernet “on the Fly”

EtherCAT is:

- faster
- Industrial Ethernet
- more flexible to wire
- easier to configure
- lower cost
- easier to implement
- well proven
- open
- safety
- redundancy
- versatile

Minimal protocol overhead via implicit addressing

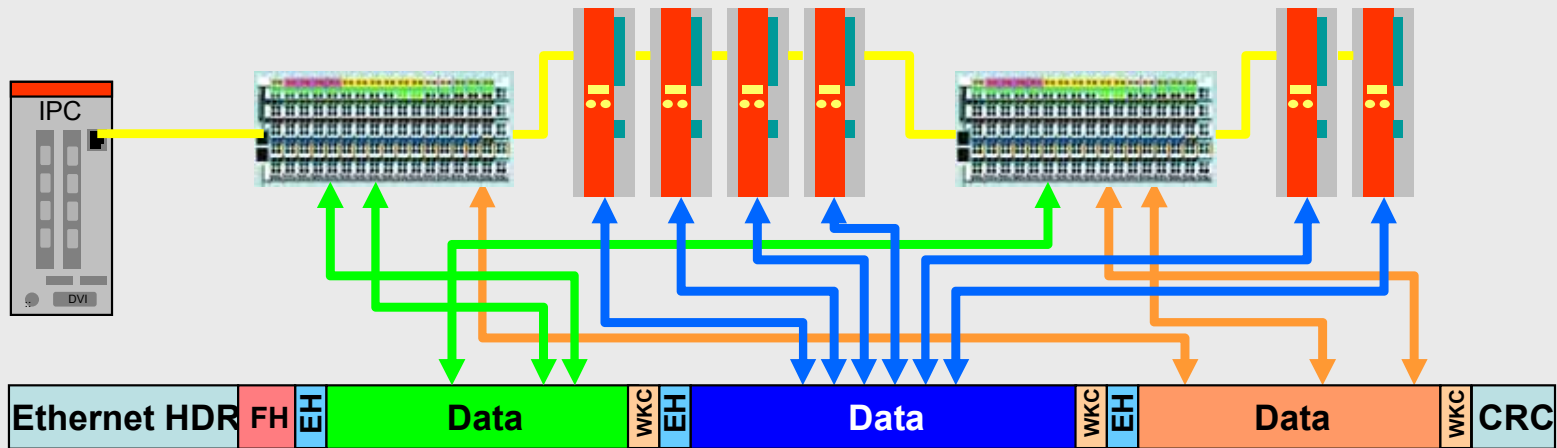

- Optimized telegram structure for decentralised I/O
- Communication completely in hardware: maximum performance
- no switches needed if only EtherCAT devices in the network
- Outstanding diagnostic features
- Ethernet-compatibility maintained

Performance: Application Example

EtherCAT is:

- faster
- Industrial Ethernet
- more flexible to wire
- easier to configure
- lower cost
- easier to implement
- well proven
- open
- safety
- redundancy
- versatile

- 40 Axis (each 20 Byte Input- and Output-Data)
- 50 I/O Station with a total of 560 EtherCAT Bus Terminals
- 2000 Digital + 200 Analog I/O, Bus Length 500 m
- Performance EtherCAT: **Cycle Time 276µs** at 44% Bus Load, Telegram Length 122µs

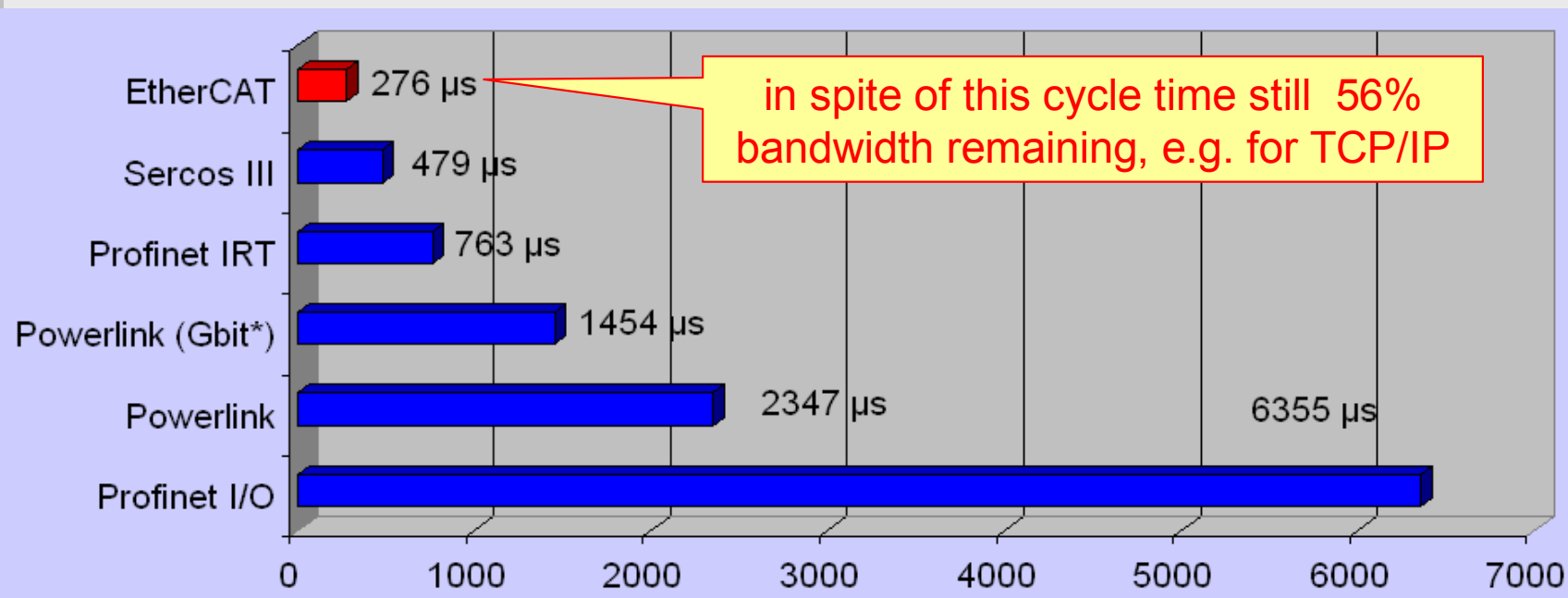

* announced. Computed with Formulas from Ethernet Powerlink Spec V 2.0, App.3

EtherCAT Propagation Delay Measurement (I)

EtherCAT is:

- faster
- Industrial Ethernet
- more flexible to wire
- easier to configure
- lower cost
- easier to implement
- well proven
- open
- safety
- redundancy
- versatile

EtherCAT Node measures time difference between leaving and returning frame

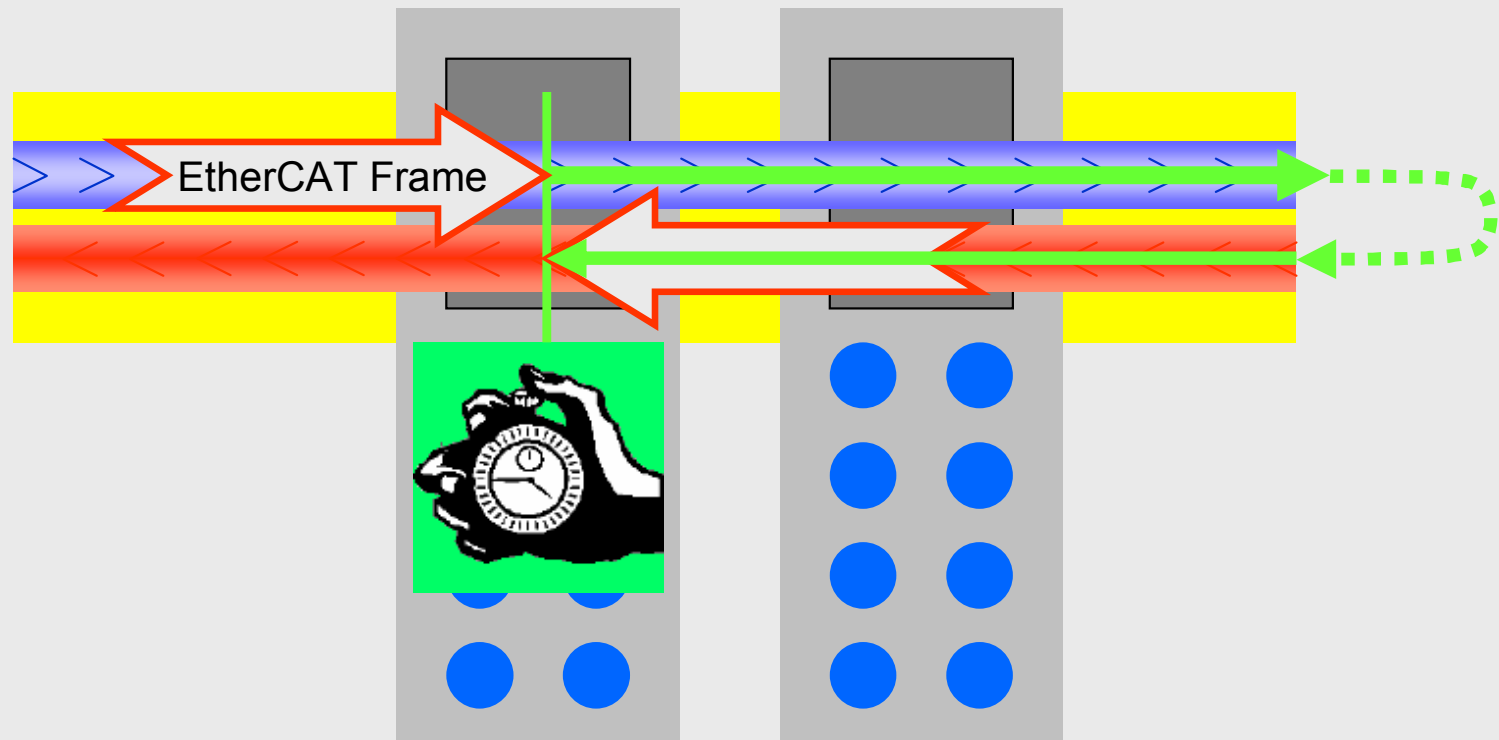

EtherCAT Propagation Delay Measurement (II)

EtherCAT is:

- faster
- Industrial Ethernet
- more flexible to wire
- easier to configure
- lower cost
- easier to implement
- well proven
- open
- safety
- redundancy
- versatile

Propagation delays between any nodes can be computed

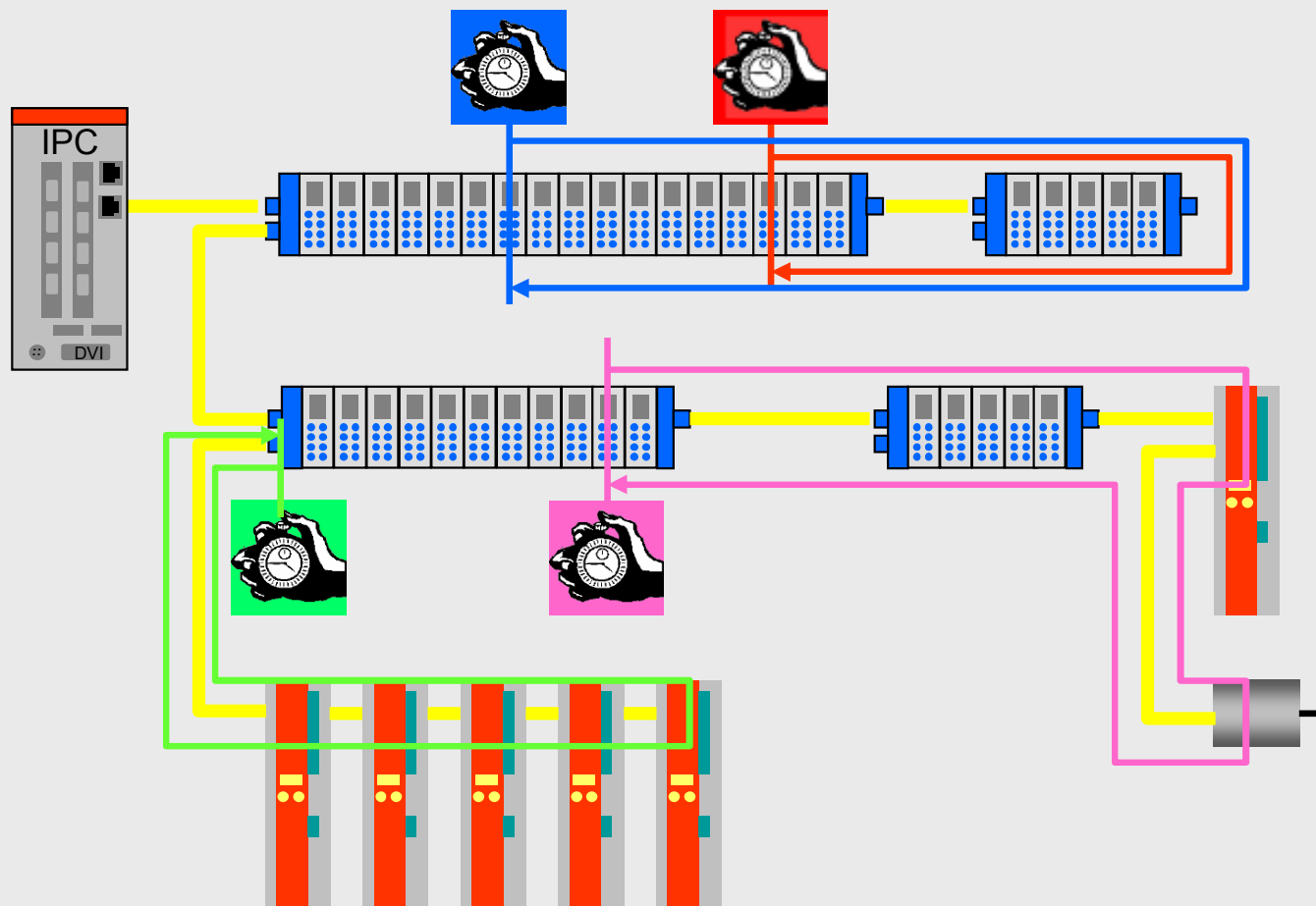

EtherCAT is:

- faster
- Industrial Ethernet
- more flexible to wire
- easier to configure
- lower cost
- easier to implement
- well proven
- open
- safety
- redundancy
- versatile

Precise Synchronisation ($\ll 1 \mu\text{s}$!) by exact adjustment of distributed clocks

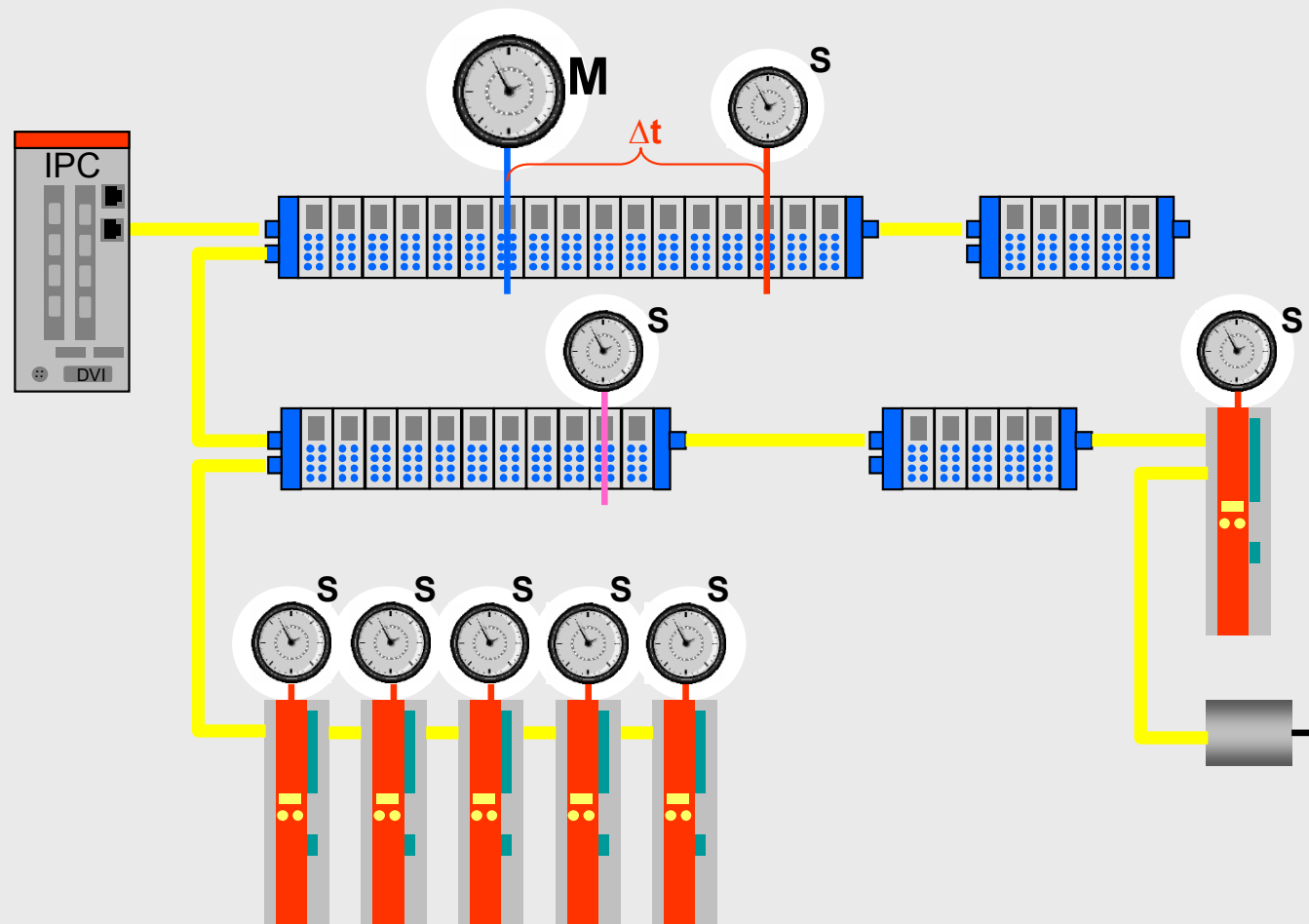

EtherCAT is:

- faster
- Industrial Ethernet
- more flexible to wire
- easier to configure
- lower cost
- easier to implement
- well proven
- open
- safety
- redundancy
- versatile

Long Term Scope View of two seperated Devices 300 Nodes in between, 120m Cable Length

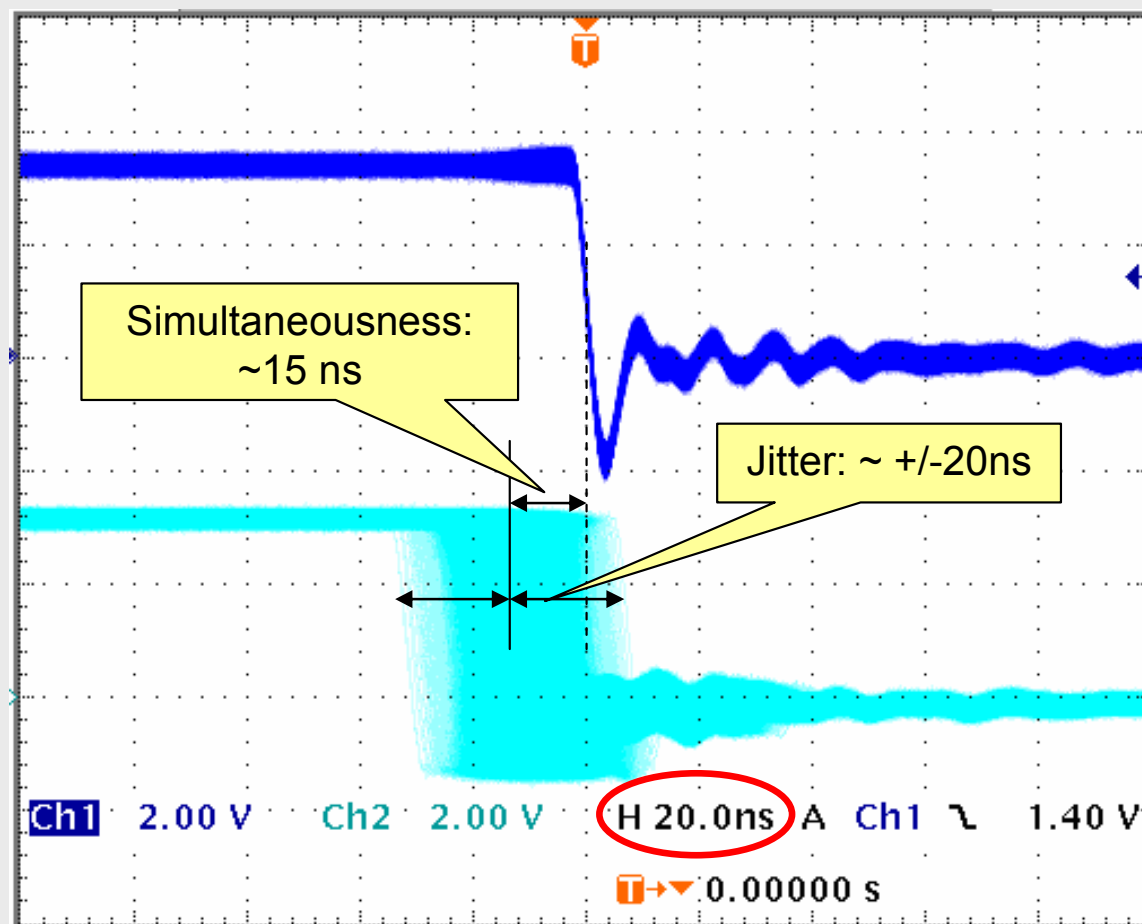

EtherCAT is Industrial Ethernet!

EtherCAT is:

- faster
- Industrial Ethernet

➤ more flexible to wire

➤ easier to configure

➤ lower cost

➤ easier to implement

➤ well proven

➤ open

➤ safety

➤ redundancy

➤ versatile

- EtherCAT uses Standard Frames: IEEE 802.3
- Alternatively via UDP/IP (if IP Routing is needed)
- no shortened Frames

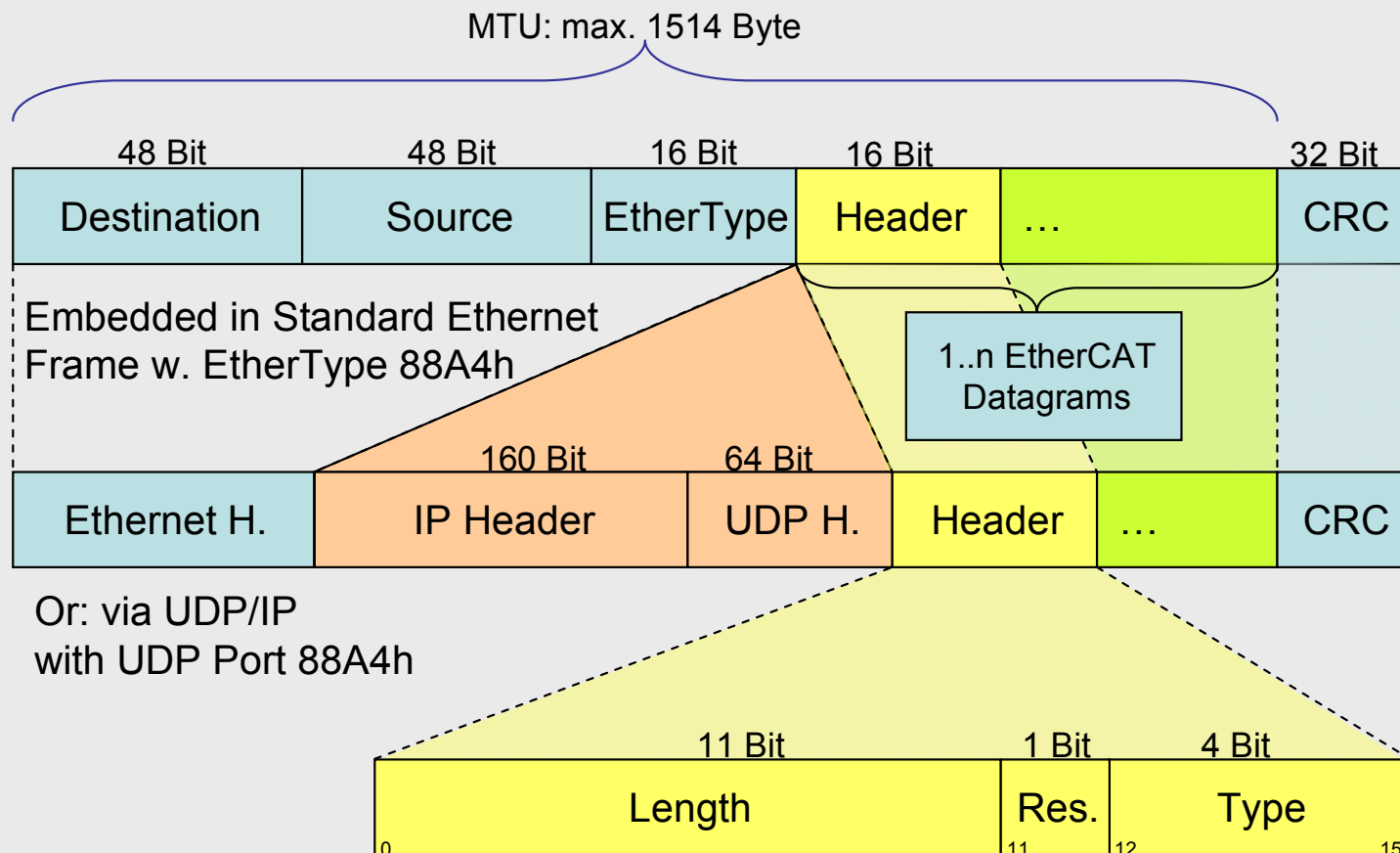

EtherCAT is Industrial Ethernet!

EtherCAT is:

- faster ✓
- Industrial Ethernet
- more flexible to wire
- easier to configure
- lower cost
- easier to implement
- well proven
- open
- safety
- redundancy
- versatile

- fully transparent for TCP/IP
- all Internet Technologies available: HTTP, FTP, ...
- without restricting the Real Time capabilities!

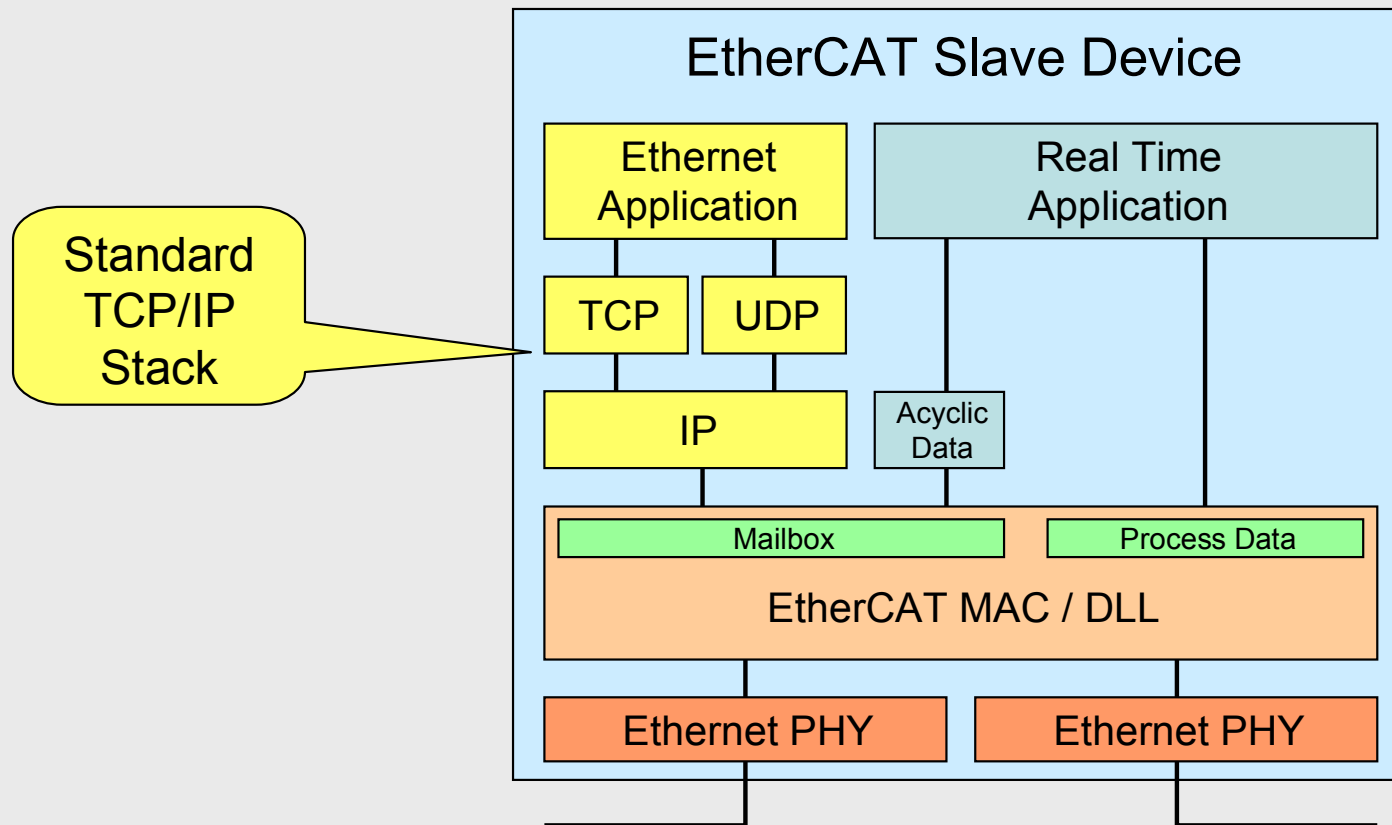

EtherCAT is Industrial Ethernet!

EtherCAT is:

- faster
- Industrial Ethernet
- more flexible to wire
- easier to configure
- lower cost
- easier to implement
- well proven
- open
- safety
- redundancy
- versatile

- Any Ethernet Device can be connected to Switchport
- Access to Webserver with Standard-Browser

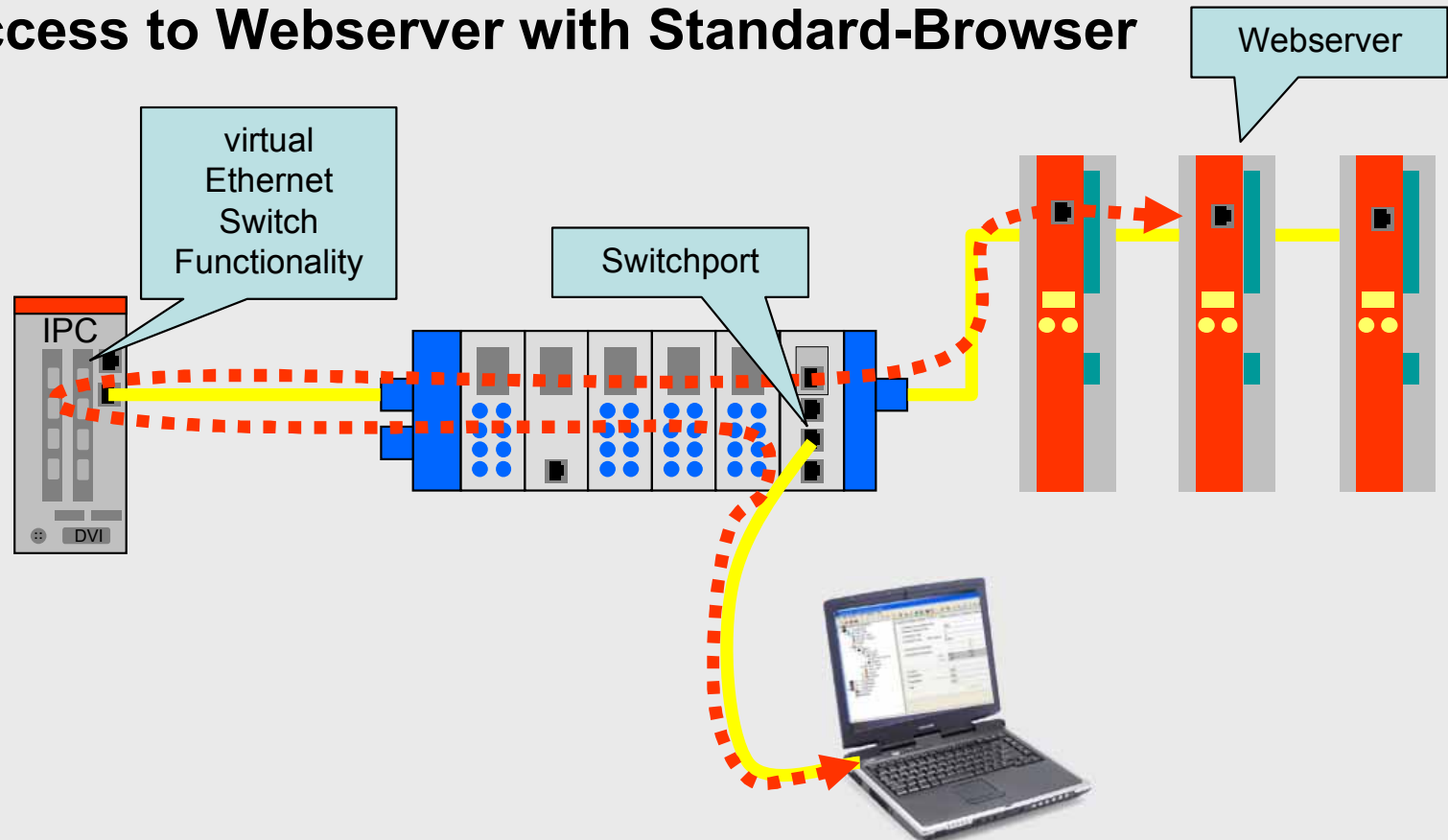

Switchport: Any Ethernet Protocol

EtherCAT is:

- faster ✓
- Industrial Ethernet

➤ more flexible to wire

➤ easier to configure

➤ lower cost

➤ easier to implement

➤ well proven

➤ open

➤ safety

➤ redundancy

➤ versatile

- Interface to any Ethernet Device or Network
- Ethernet Frames are inserted into EtherCAT Protocol
- “Ethernet over EtherCAT”

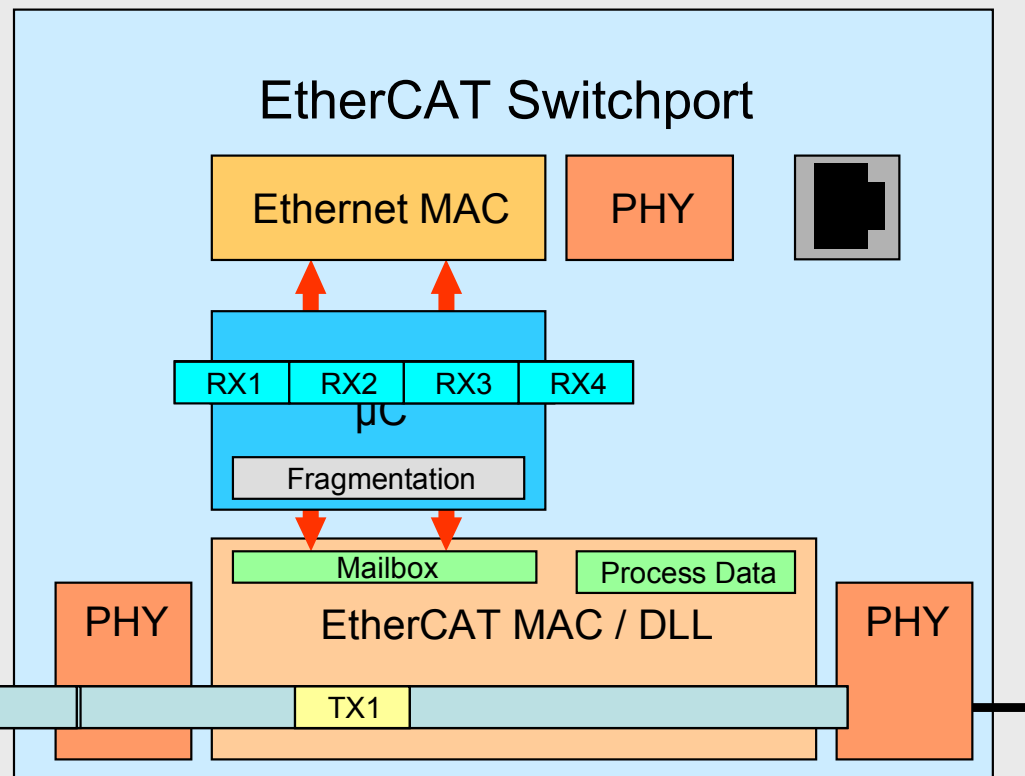

EtherCAT is Industrial Ethernet!

EtherCAT is:

- faster ✓
- Industrial Ethernet
- more flexible to wire
- easier to configure
- lower cost
- easier to implement
- well proven
- open
- safety
- redundancy
- versatile

- **Virtual Ethernet Switch routes any Ethernet Frame**
- **From inside as well as from outside the segment**

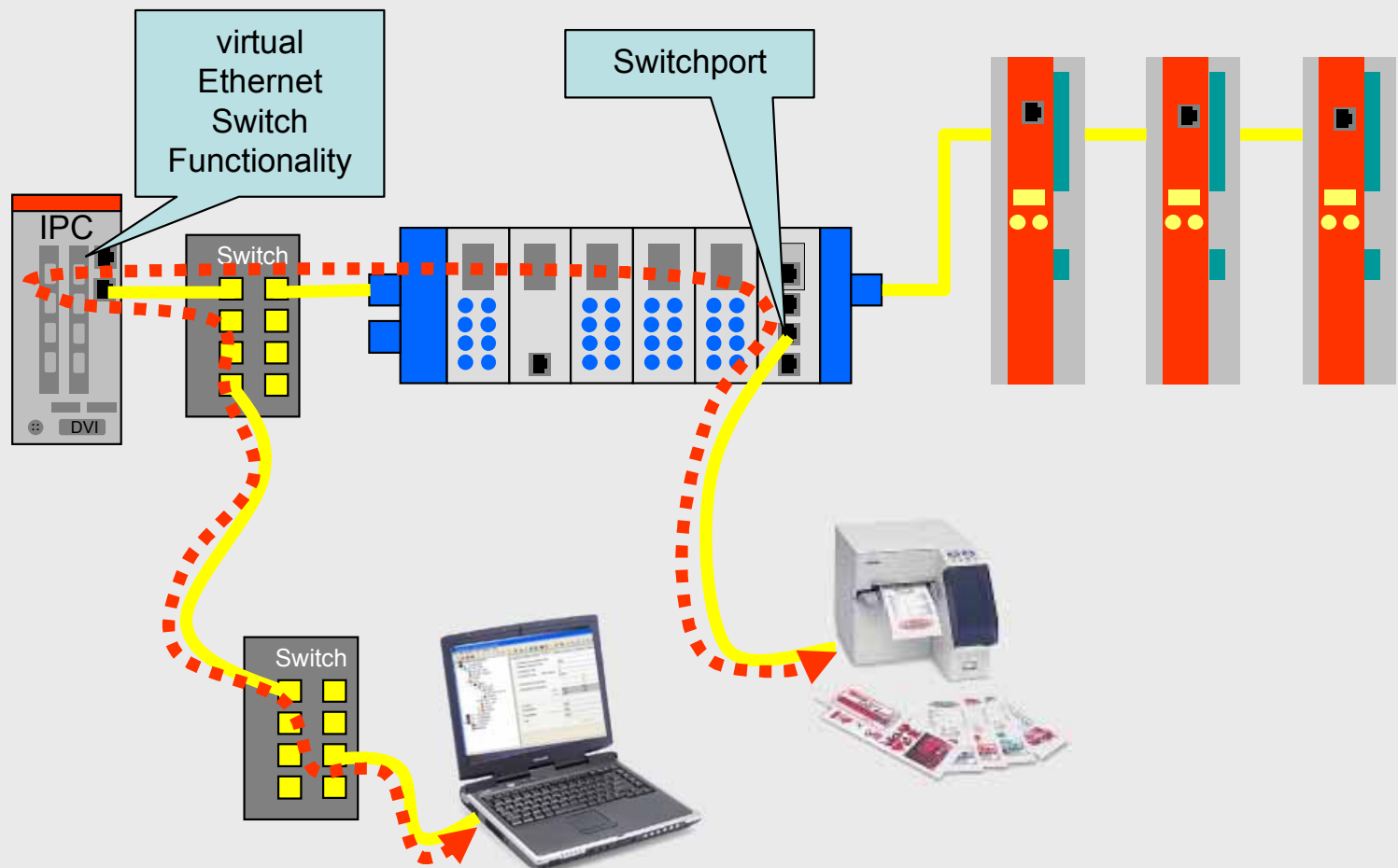

EtherCAT: Flexible System Architecture

EtherCAT is:

- faster ✓
- Industrial Ethernet
- more flexible to wire
- easier to configure
- lower cost
- easier to implement
- well proven
- open
- safety
- redundancy
- versatile

Master ↔ Slave

Master ↔ Master

Slave ↔ Slave

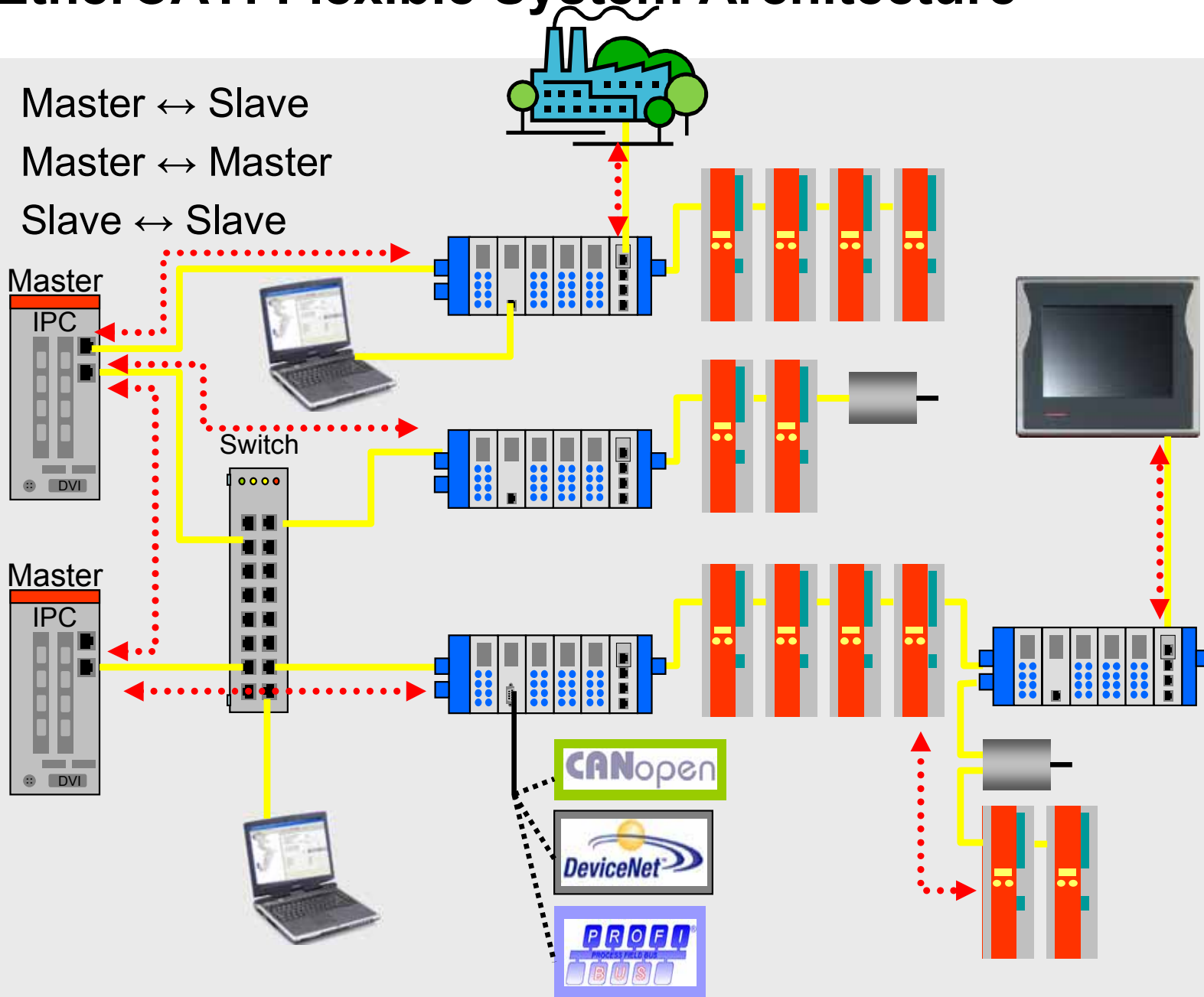

EtherCAT wiring is more flexible

EtherCAT is:

- faster ✓
- Industrial Ethernet ✓
- more flexible to wire
- easier to configure
- lower cost
- easier to implement
- well proven
- open
- safety
- redundancy
- versatile

Standard Ethernet Topology: Star

not ideal – here a test setup for demo purposes ;-)

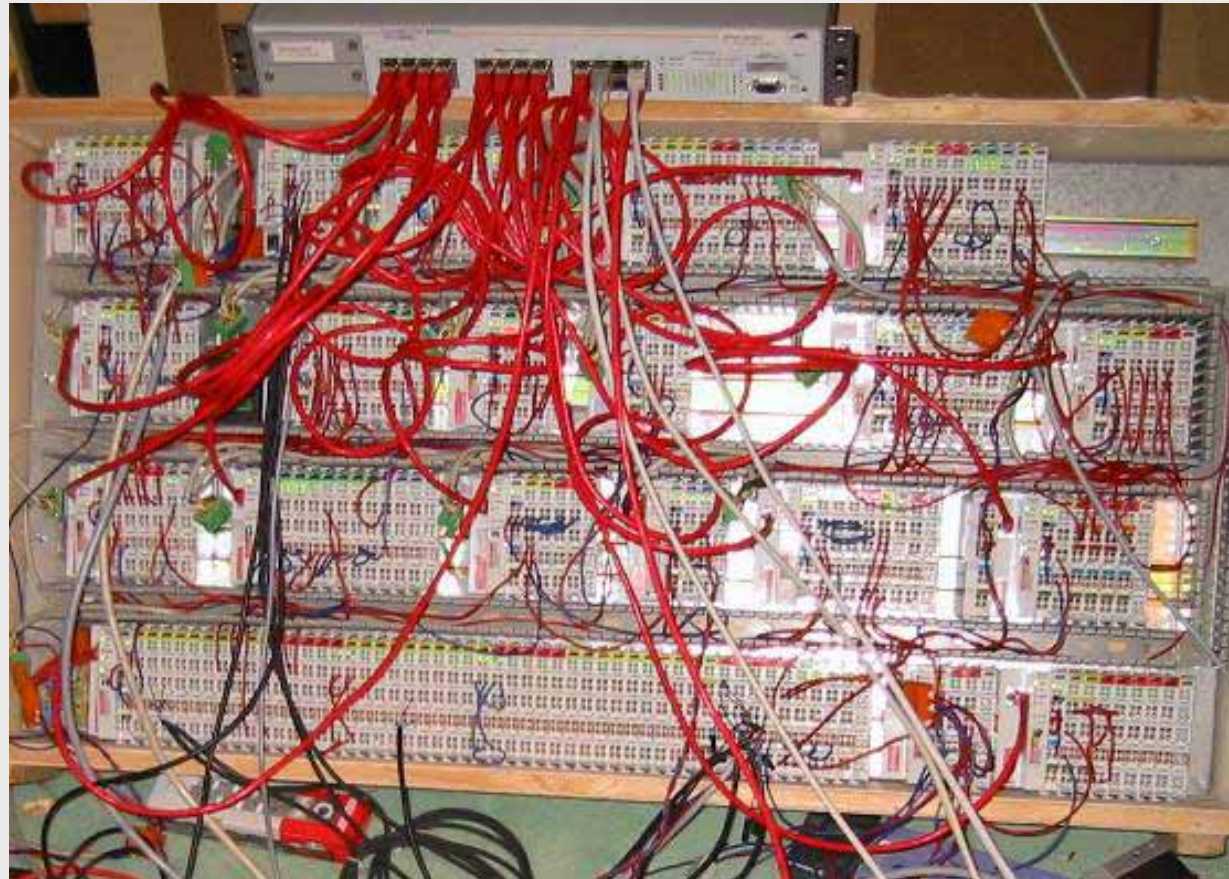

EtherCAT wiring is more flexible

EtherCAT is:

- faster ✓
- Industrial Ethernet ✓
- more flexible to wire
- easier to configure
- lower cost
- easier to implement
- well proven
- open
- safety
- redundancy
- versatile

Line-Topology: any number of nodes lined up

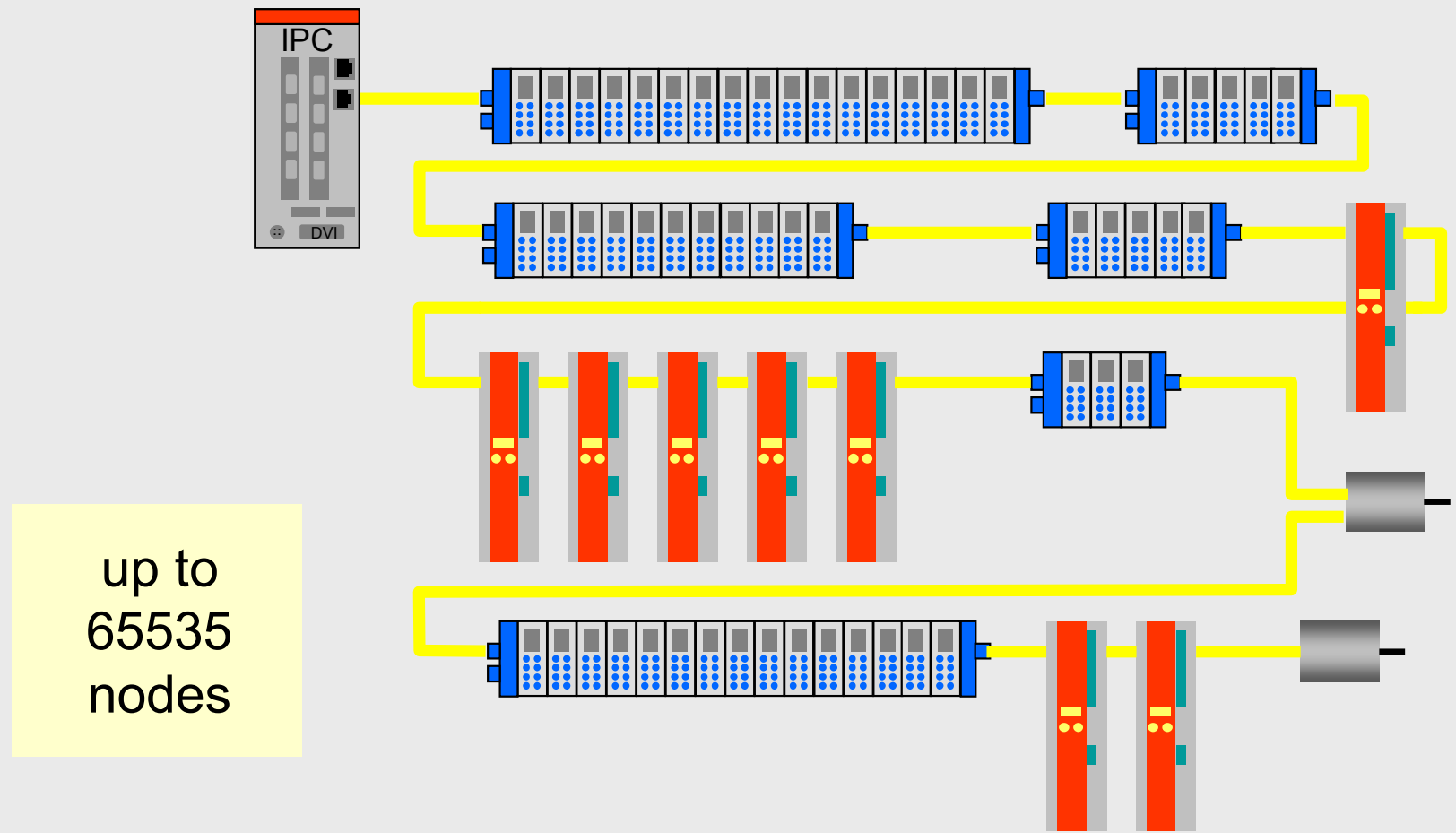

EtherCAT wiring is more flexible

EtherCAT is:

- faster ✓
- Industrial Ethernet ✓
- more flexible to wire
- easier to configure
- lower cost
- easier to implement
- well proven
- open
- safety
- redundancy
- versatile

Topology-Variant: "Daisy Chain"

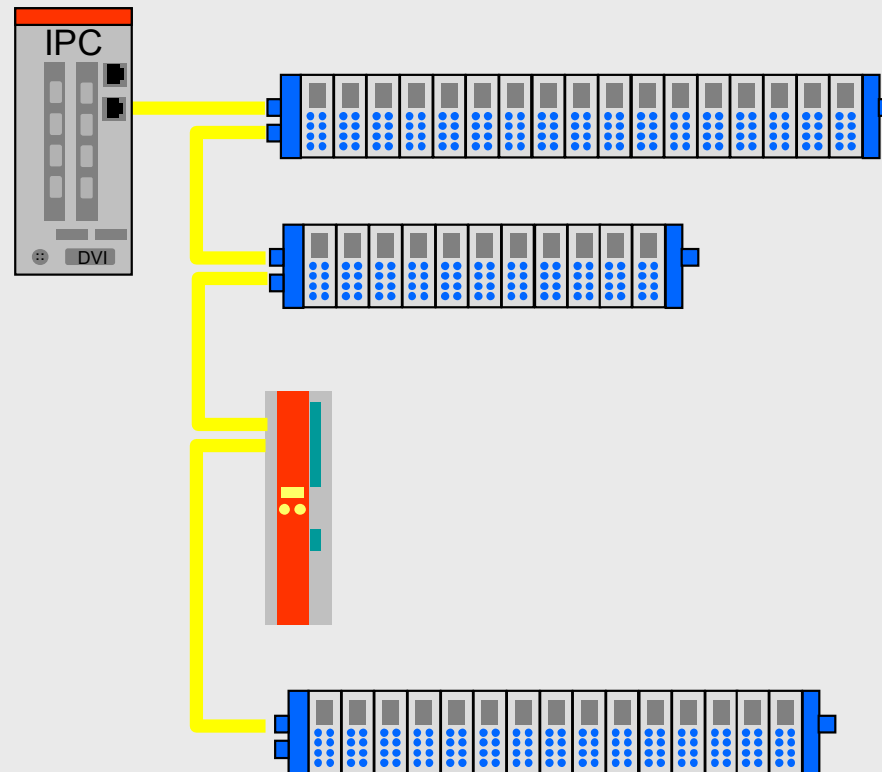

Cable: Standard CAT5 Cable
without "Crossover"

EtherCAT wiring is more flexible

EtherCAT is:

- faster ✓
- Industrial Ethernet ✓
- more flexible to wire
- easier to configure
- lower cost
- easier to implement
- well proven
- open
- safety
- redundancy
- versatile

Topology-Variant: "Daisy Chain" with Drop Lines

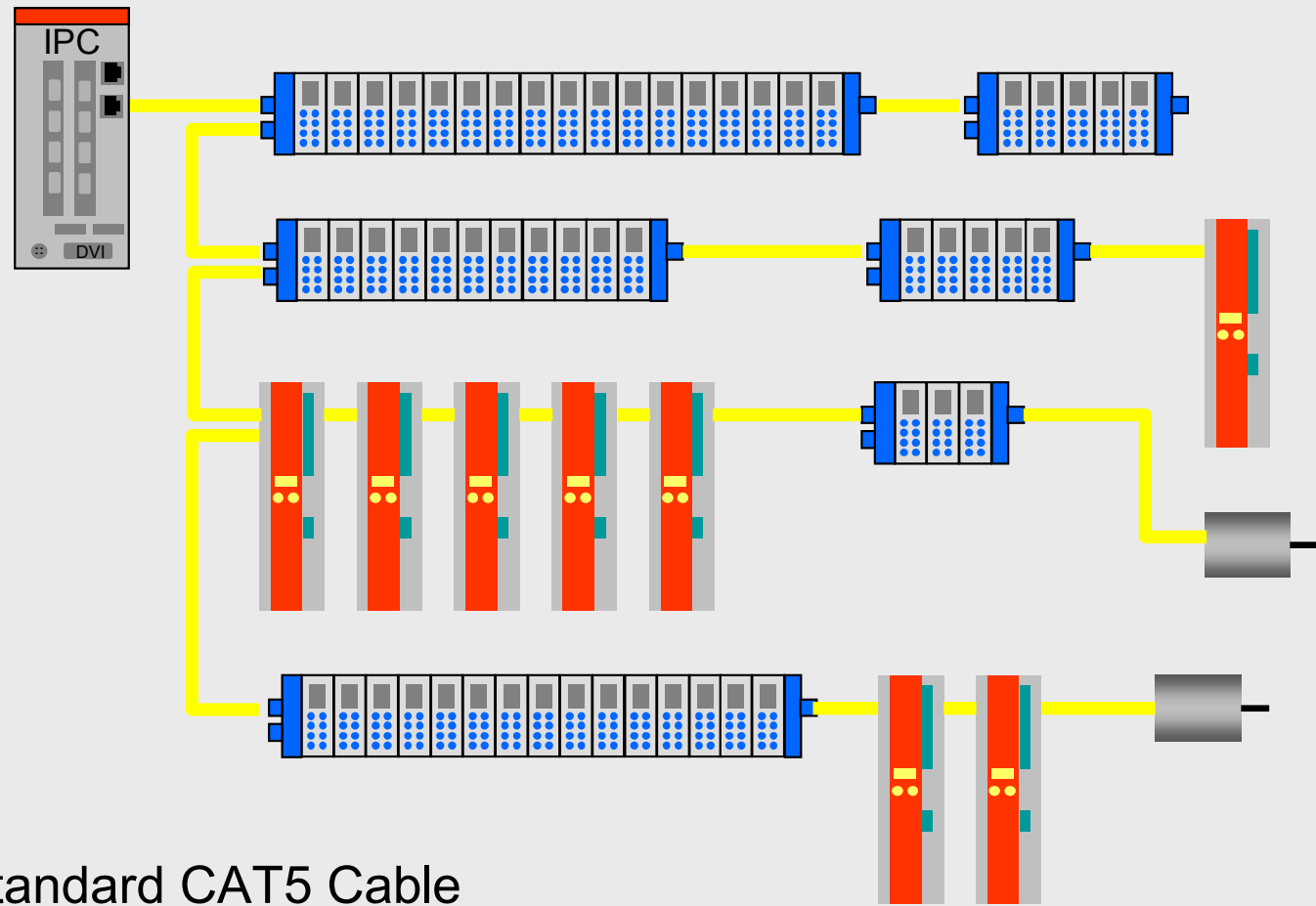

Cable: Standard CAT5 Cable without "Crossover"

EtherCAT wiring is more flexible

EtherCAT is:

- faster ✓
- Industrial Ethernet ✓
- more flexible to wire
- easier to configure
- lower cost
- easier to implement
- well proven
- open
- safety
- redundancy
- versatile

flexible tree structures – arbitrarily extendable

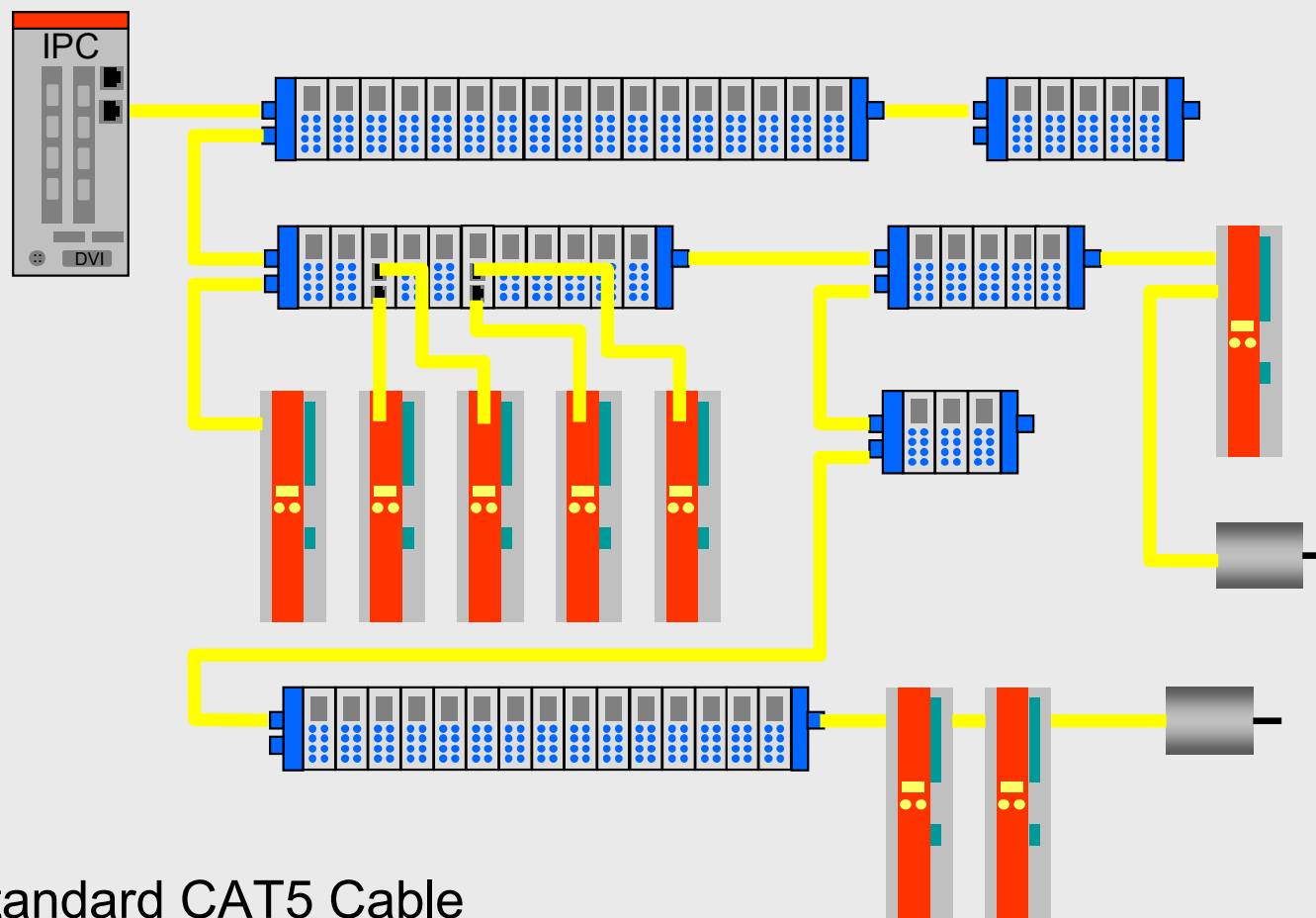

Cable: Standard CAT5 Cable
without "Crossover"

EtherCAT instead of PCI

EtherCAT is:

- faster ✓
- Industrial Ethernet ✓
- more flexible to wire
- easier to configure
- lower cost
- easier to implement
- well proven
- open
- safety
- redundancy
- versatile

Protection of your investment:

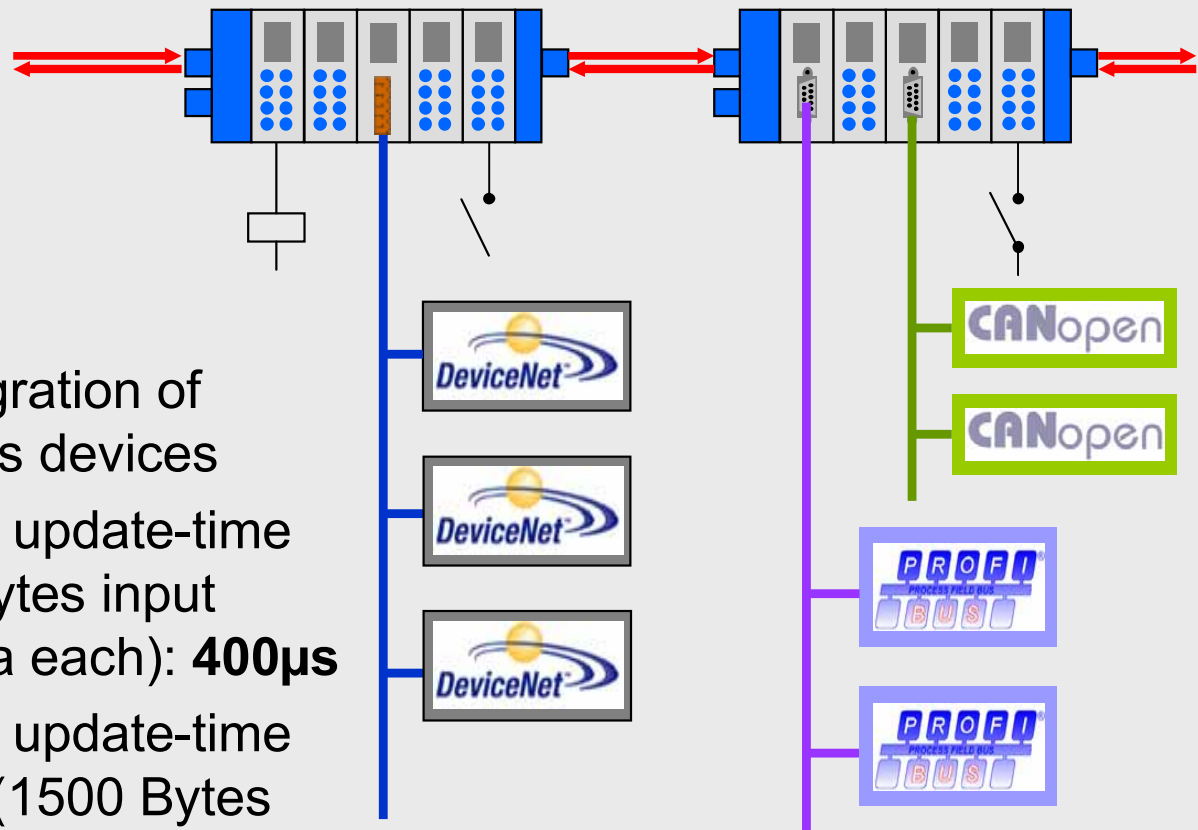

- Seamless integration of existing fieldbus devices
- Process image update-time via **PCI** (500 Bytes input and output data each): **400µs**
- Process image update-time via **EtherCAT** (1500 Bytes input and output data): **150µs**

EtherCAT instead of PCI

EtherCAT is:

- faster ✓
- Industrial Ethernet ✓
- more flexible to wire
- easier to configure
- lower cost
- easier to implement
- well proven
- open
- safety
- redundancy
- versatile

- No Slots in Control System (IPC or SPS) required any more
- Nevertheless maximum expandability



EtherCAT instead of PCI

EtherCAT is:

- faster ✓
- Industrial Ethernet ✓
- more flexible to wire
- easier to configure
- lower cost
- easier to implement
- well proven
- open
- safety
- redundancy
- versatile

- No Slots in Control System (IPC or SPS) required any more
- Nevertheless maximum expandability

EtherCAT



EtherCAT is easier to configure

EtherCAT is:

- faster ✓
- Industrial Ethernet ✓
- more flexible to wire ✓

➤ easier to configure

- lower cost
- easier to implement
- well proven
- open
- safety
- redundancy
- versatile

Addressing:

- No manual address setting required
- Addresses can be assigned automatically
- Addresses can be kept – no new addressing if nodes are added

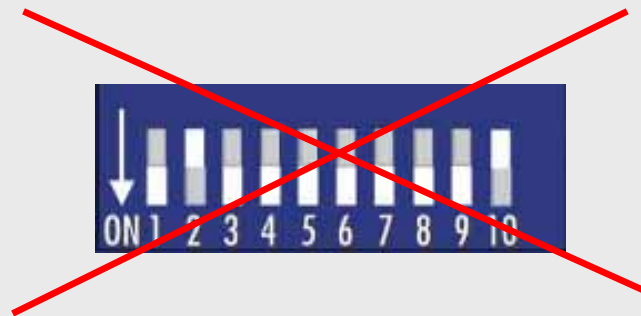

EtherCAT is easier to configure

EtherCAT is:

- faster ✓
- Industrial Ethernet ✓
- more flexible to wire ✓
- easier to configure
- lower cost
- easier to implement
- well proven
- open
- safety
- redundancy
- versatile

Topology:

- Automatic topology target/actual comparison

Diagnosis:

- Diagnosis with exact localisation

Network planning:

- Performance independent of:
 - Slave implementation
 - Topology (no Switches/Hubs)

EtherCAT is lower costs



EtherCAT is:

- faster ✓
- Industrial Ethernet ✓
- more flexible to wire ✓
- easier to configure ✓
- lower cost
- easier to implement
- well proven
- open
- safety
- redundancy
- versatile



Master:

no dedicated plug in card (co-processor), on-board Ethernet Port is fine



Slave:

- low cost Slave Controller
- FPGA or ASIC
- no powerful μ C needed





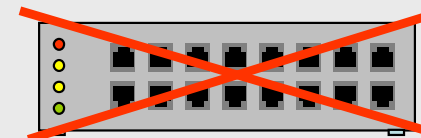

Infrastructure:

- no Switches/Hubs required
- Standard Ethernet Cabling



EtherCAT Slave Controller Overview

EtherCAT is:

- faster 
- Industrial Ethernet 
- more flexible to wire 
- easier to configure 
- lower cost 
- easier to implement
- well proven
- open
- safety
- redundancy
- versatile

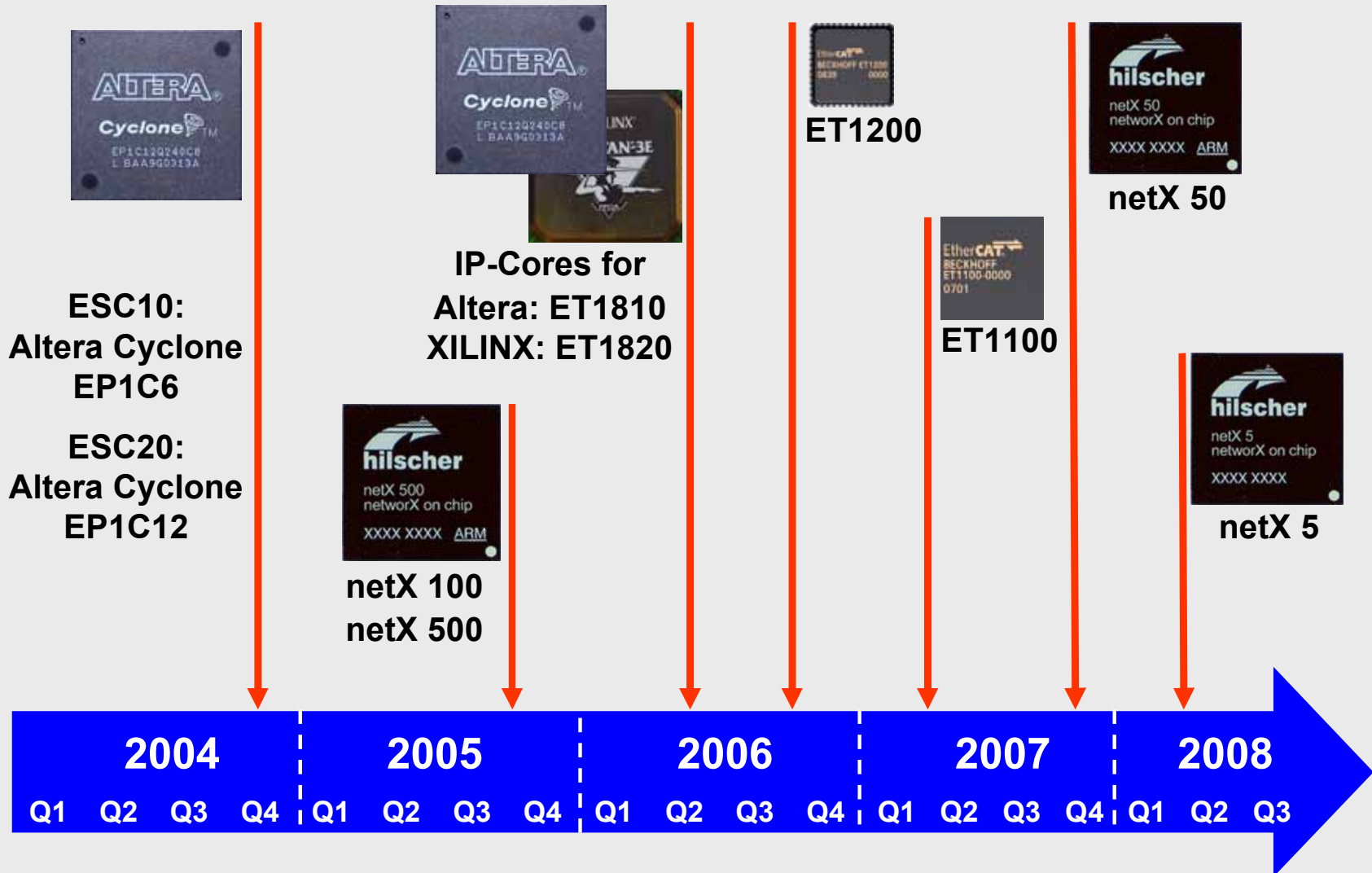

EtherCAT Slave Implementation

EtherCAT is:

- faster ✓
- Industrial Ethernet ✓
- more flexible to wire ✓
- easier to configure ✓
- lower cost ✓
- easier to implement
- well proven
- open
- safety
- redundancy
- versatile

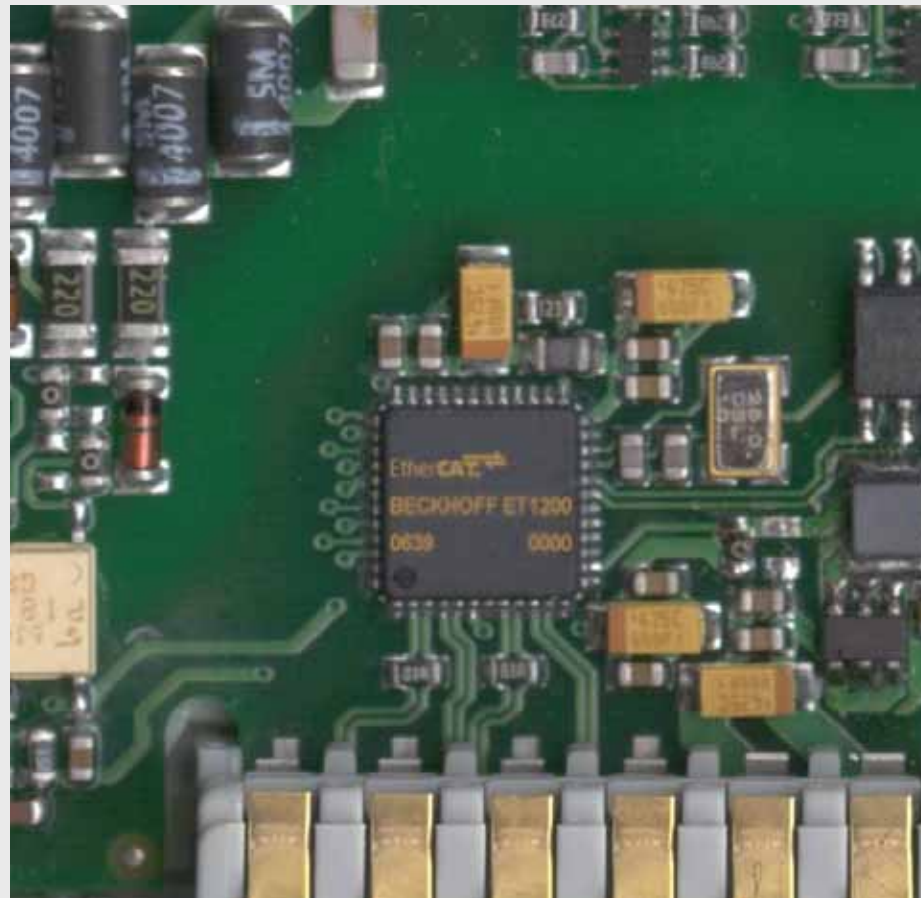

EtherCAT Interface for I/O Terminal, ET1200 ASIC (Beckhoff)

EtherCAT Slave Implementation

EtherCAT is:

- faster ✓
- Industrial Ethernet ✓
- more flexible to wire ✓
- easier to configure ✓
- lower cost ✓
- easier to implement
- well proven
- open
- safety
- redundancy
- versatile

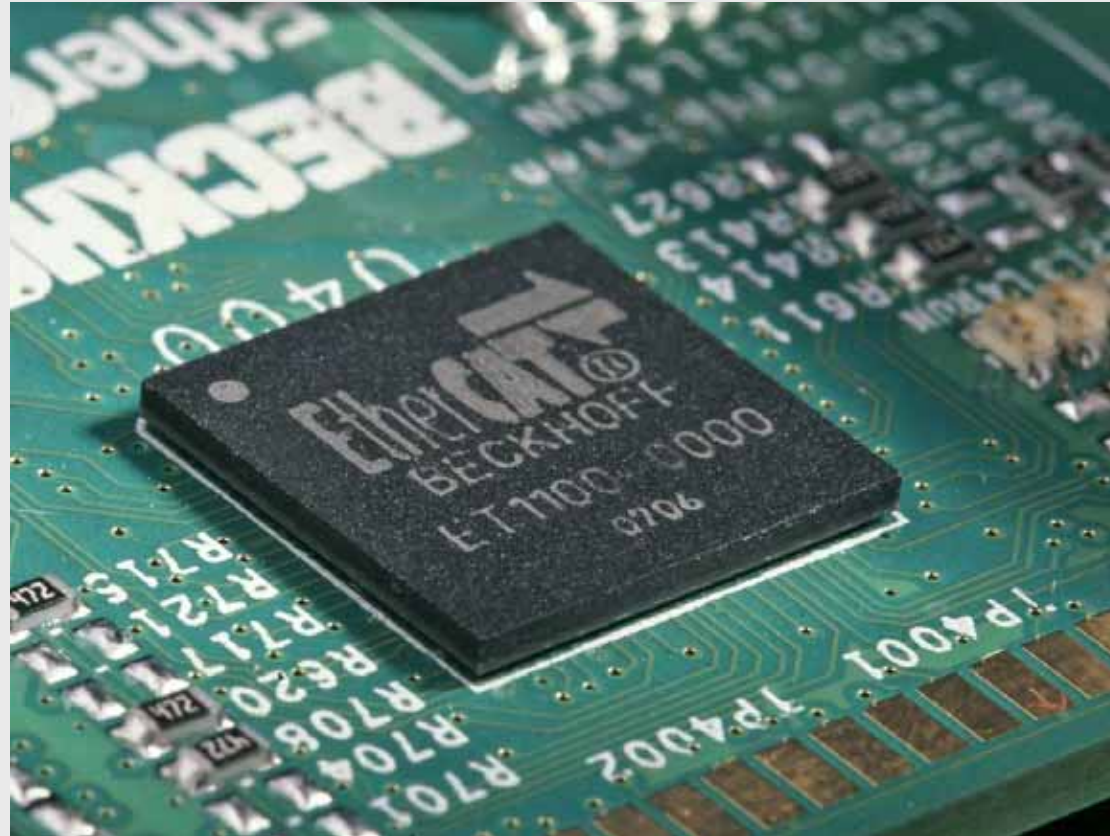

EtherCAT Interface with ET1100 ASIC
(Beckhoff)

EtherCAT Slave Implementation

EtherCAT is:

- faster ✓
- Industrial Ethernet ✓
- more flexible to wire ✓
- easier to configure ✓
- lower cost ✓
- easier to implement
- well proven
- open
- safety
- redundancy
- versatile



EtherCAT Interface, NETX 500
(Hilscher)

EtherCAT Slave Implementation

EtherCAT is:

- faster ✓
- Industrial Ethernet ✓
- more flexible to wire ✓
- easier to configure ✓
- lower cost ✓
- easier to implement
- well proven
- open
- safety
- redundancy
- versatile

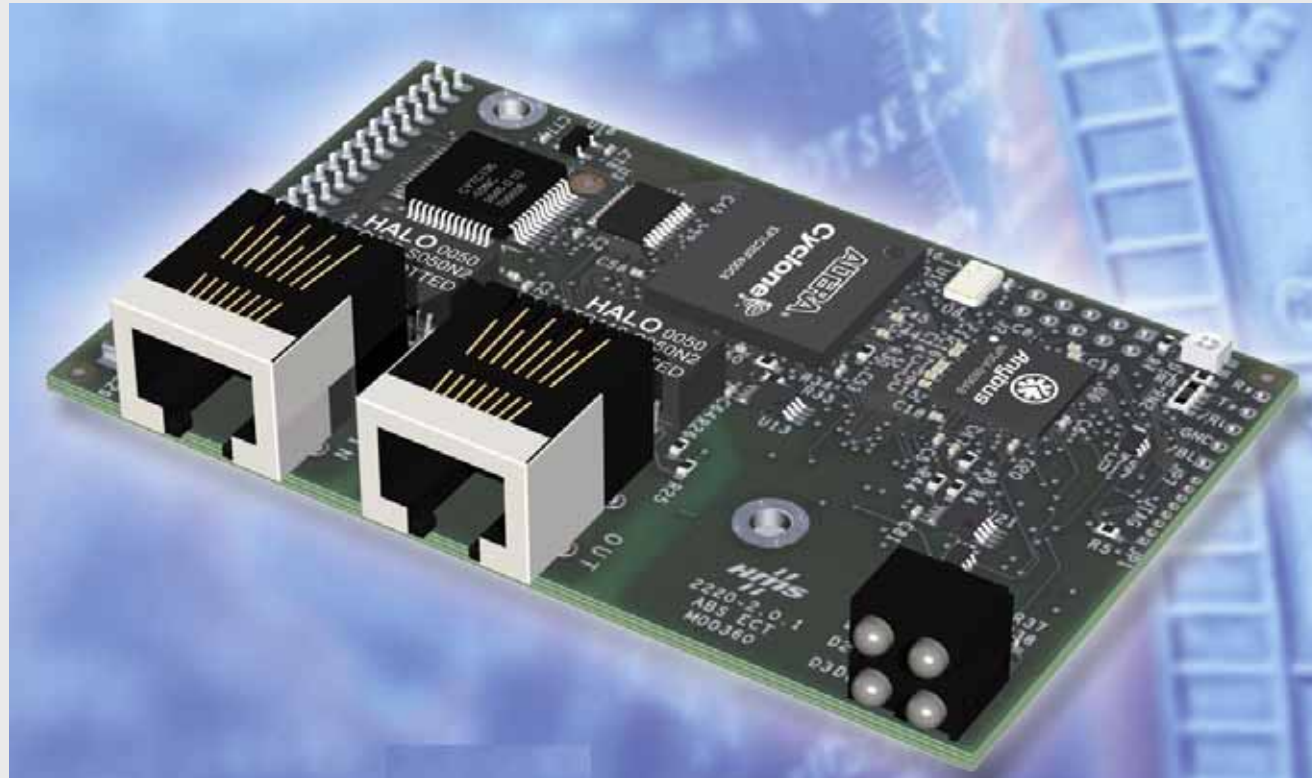

EtherCAT Interface Board, Anybus-S
(HMS)

EtherCAT Slave Controller without Host CPU

EtherCAT is:

- faster ✓
- Industrial Ethernet ✓
- more flexible to wire ✓
- easier to configure ✓
- lower cost ✓
- easier to implement
- well proven
- open
- safety
- redundancy
- versatile

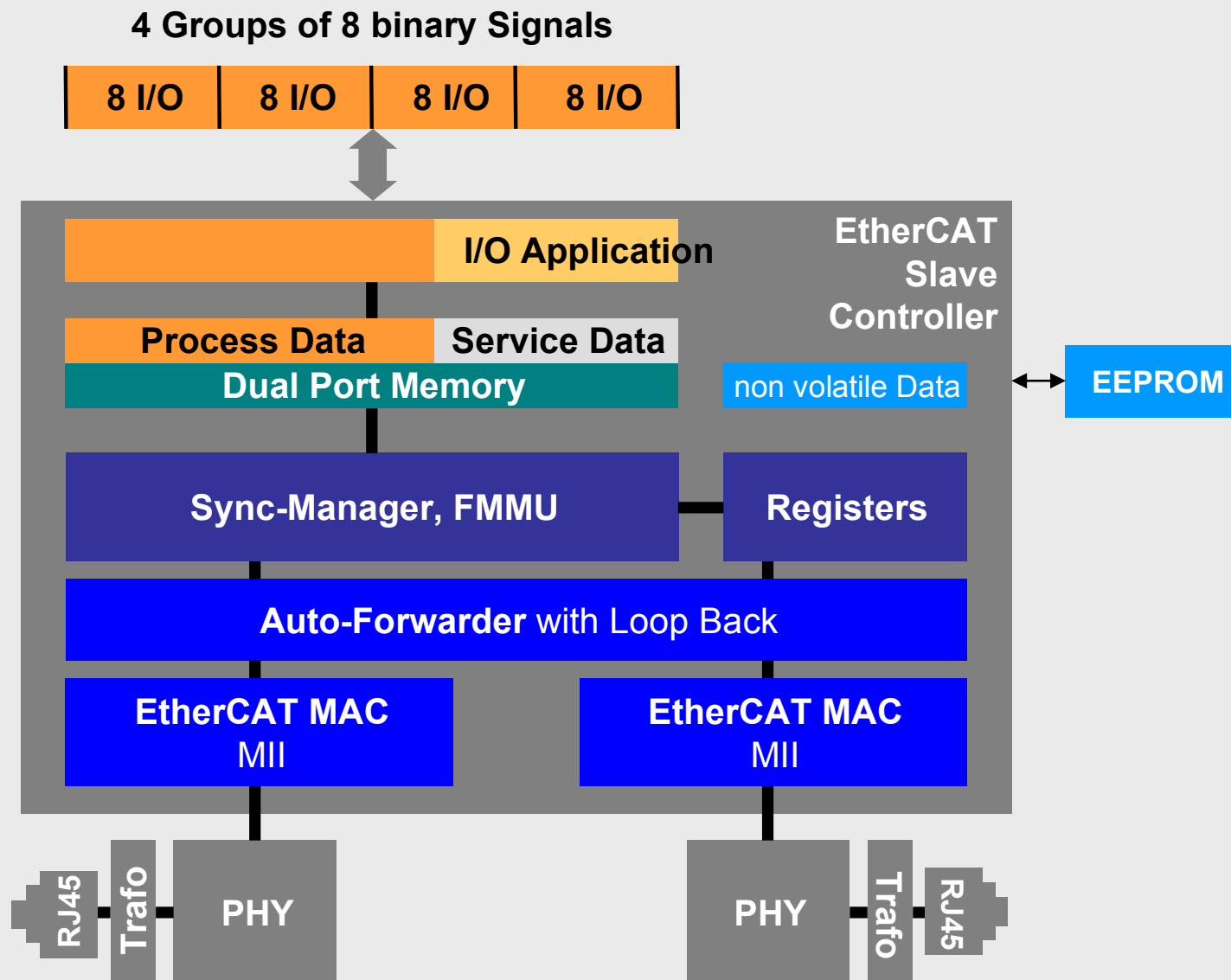

EtherCAT Slave Controller with Host CPU

EtherCAT is:

- faster ✓
- Industrial Ethernet ✓
- more flexible to wire ✓
- easier to configure ✓
- lower cost ✓
- easier to implement
- well proven
- open
- safety
- redundancy
- versatile

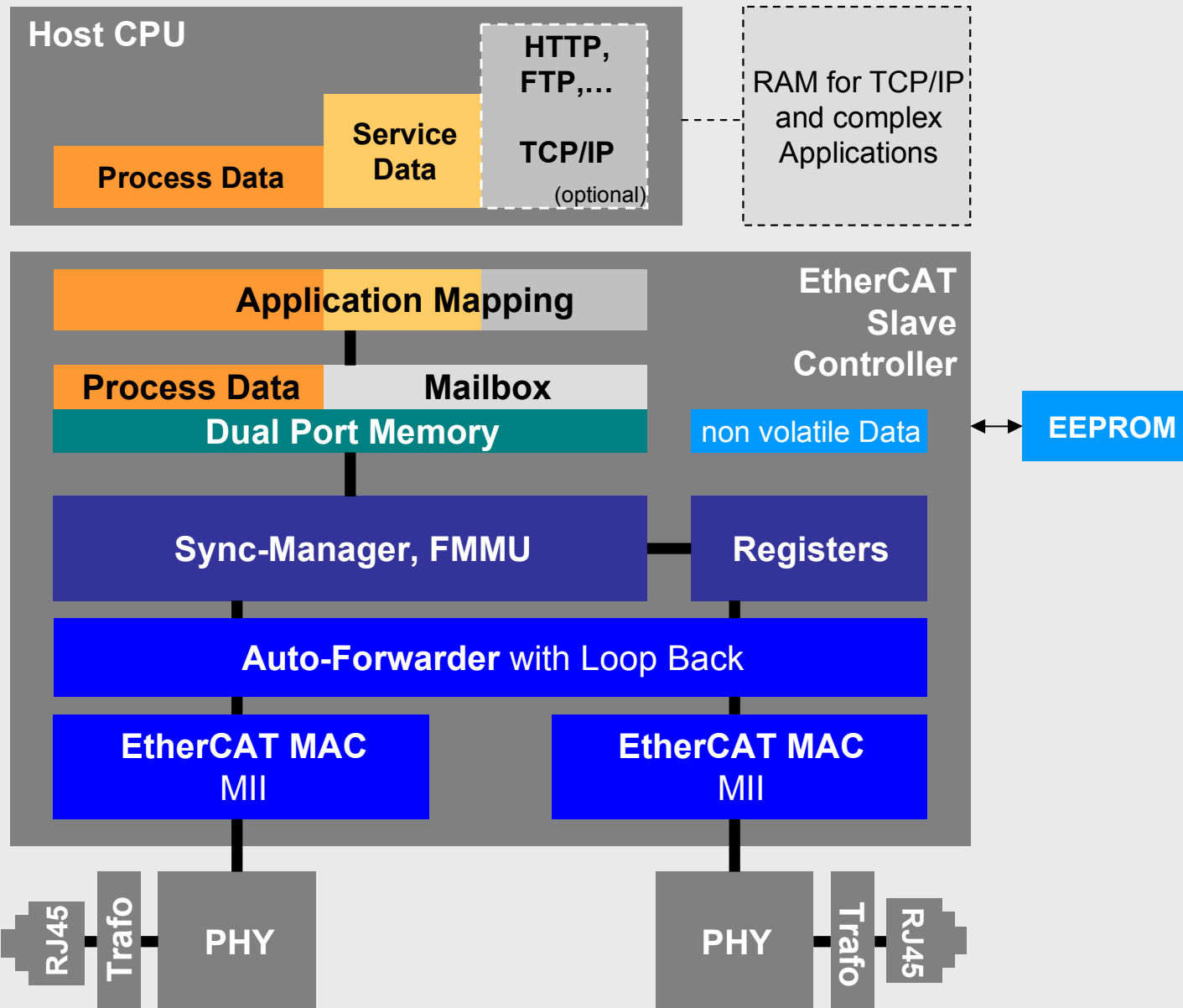

EtherCAT Slave Evaluation Kit by Beckhoff

EtherCAT is:

- faster ✓
- Industrial Ethernet ✓
- more flexible to wire ✓
- easier to configure ✓
- lower cost ✓
- easier to implement
- well proven
- open
- safety
- redundancy
- versatile

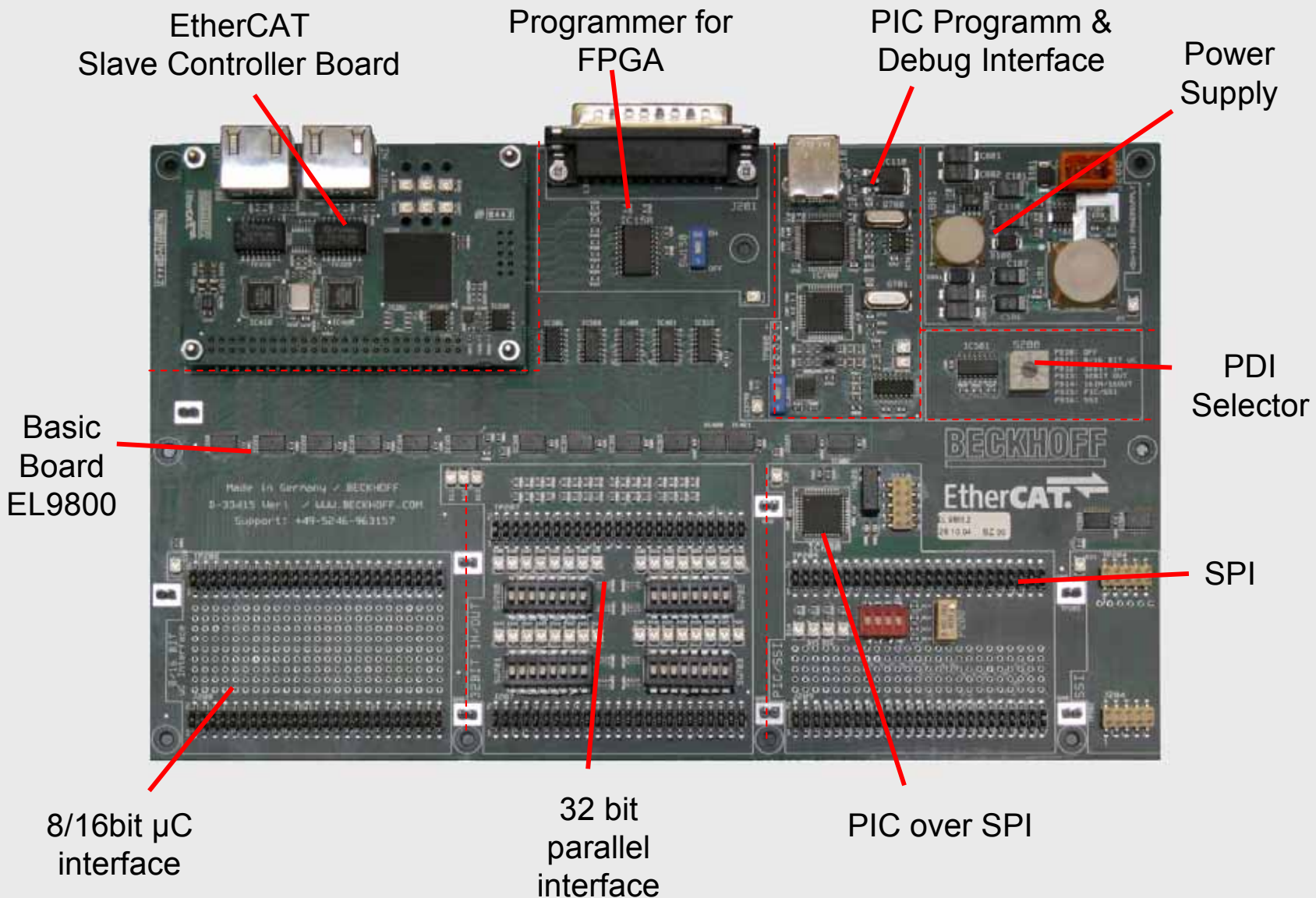

Slave Evaluation Kit by EBV

EtherCAT is:

- faster ✓
- Industrial Ethernet ✓
- more flexible to wire ✓
- easier to configure ✓
- lower cost ✓
- easier to implement
- well proven
- open
- safety
- redundancy
- versatile

Overview

- The DBC2C20 is a Cyclone II Development Board with several I/O transceiver for industrial communication purposes. The following features are integrated:
- EP2C20F484C7
- LVDS TFT interface
- 16Mbyte SDRAM
- 1Mbyte SRAM
- 8Mbyte flash
- 2x CAN transceiver
- 4x RS485 transceiver
- 2x 12 pin connector
- 16bit 24V I/O interface
- 8x User LEDs
- 2 digit seven segment display
- on board 3.3V / 1.2V power supply



EtherCAT is:

- faster ✓
- Industrial Ethernet ✓
- more flexible to wire ✓
- easier to configure ✓
- lower cost ✓
- easier to implement
- well proven
- open
- safety
- redundancy
- versatile

netX 100 Starter Board Overview

- NXSB100 Board
- EtherCAT Slave Evaluation Plattform with/for NetX100
- The most economical way of familiarizing oneself with the software development of the netX.
- 4 MByte of Flash and 8 MByte SDRAM.
- A RS232C, a USB and a JTAG interface are available for loading and debugging.
- Two EtherCAT Ports, a PROFIBUS and a DeviceNet interface are available for communication. The Dual-port-memory that can also be configured as extension bus or general I/Os are output on a pin strip



Microcontroller Requirements (Slave Host CPU)

EtherCAT is:

- faster ✓
- Industrial Ethernet ✓
- more flexible to wire ✓
- easier to configure ✓
- lower cost ✓
- easier to implement
- well proven
- open
- safety
- redundancy
- versatile

- Simple (I/O) Devices do not require a μ C at all
- Tasks of μ C in more complex devices:
 - Process data – Exchange with the application
 - Object Dictionary Handling
 - Handling of Application Parameter (Communication Parameter are handled by ESC)
 - TCP/IP Stack Handling – if required
- μ C-Performance is determined by Device Application, not by EtherCAT Communication
→ In many cases an 8bit μ C is sufficient

EtherCAT is easier to implement

EtherCAT is:

- faster ✓
- Industrial Ethernet ✓
- more flexible to wire ✓
- easier to configure ✓
- lower cost ✓
- easier to implement
- well proven
- open
- safety
- redundancy
- versatile

Master:

- Master Sample Code (Source)
- EtherCAT configuration tool

- XML Data formats

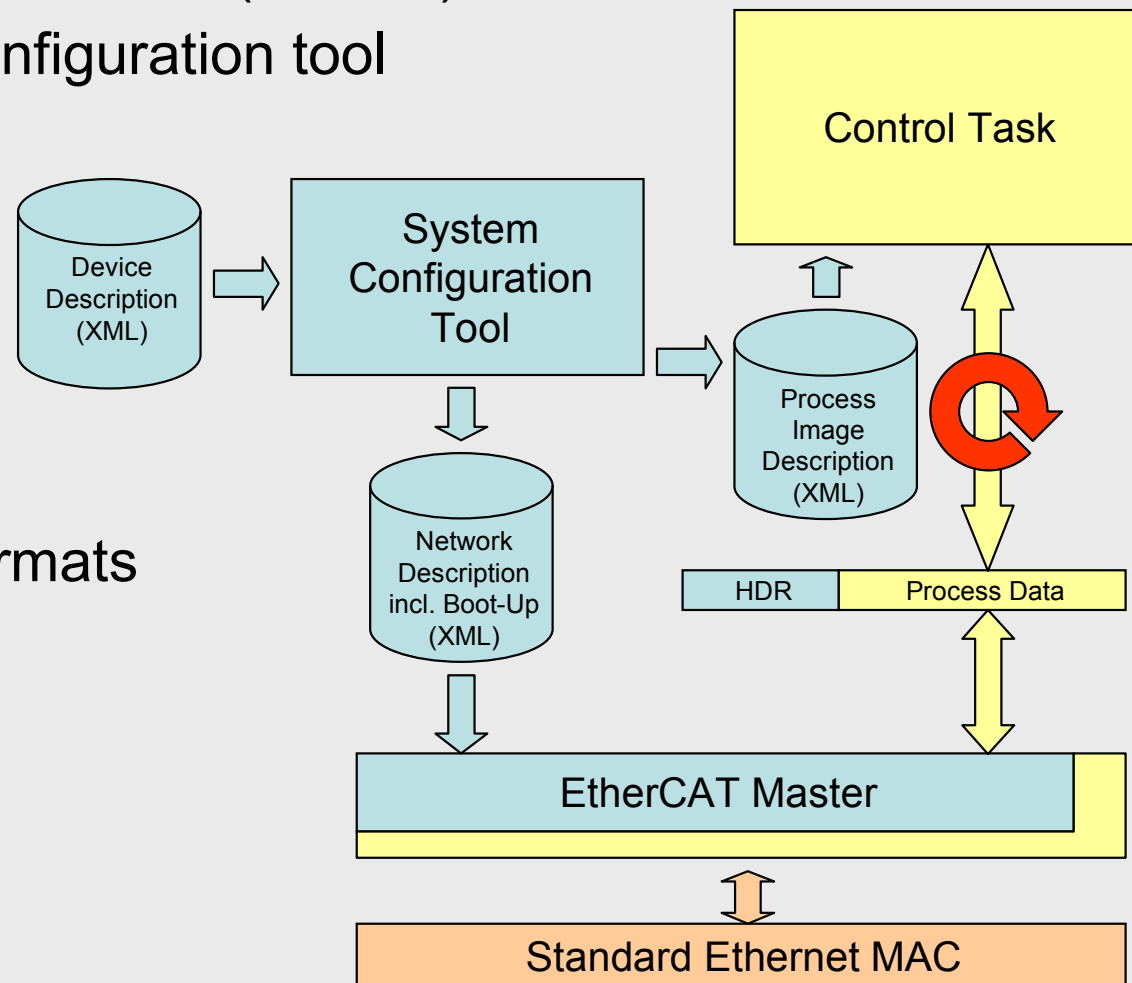

EtherCAT is easier to implement

EtherCAT is:

- faster ✓
- Industrial Ethernet ✓
- more flexible to wire ✓
- easier to configure ✓
- lower cost ✓
- easier to implement
- well proven
- open
- safety
- redundancy
- versatile

Example: Master with just one process image:

- typical e.g. for small controllers with one control task
- up to 1488 Byte Process data size
- **Header for Process Data Communication remains constant**

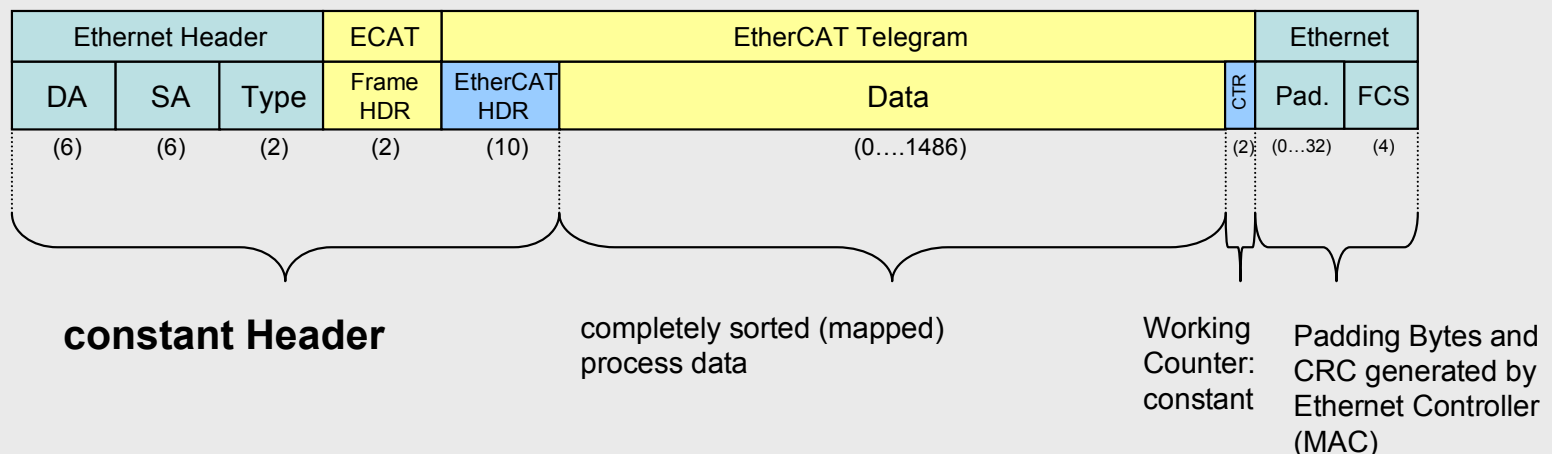

- Master can be implemented with minimal effort
- No separate communication processor required (e.g. on plug-in card)
- **Much simpler than legacy fieldbus systems**
- **Very much simpler than competing Industrial Ethernet approaches...**

Master Implementations: RTOS

EtherCAT is:

- faster ✓
- Industrial Ethernet ✓
- more flexible to wire ✓
- easier to configure ✓
- lower cost ✓
- easier to implement
- well proven
- open
- safety
- redundancy
- versatile

Selection of Real Time Operating Systems used with EtherCAT Masters:

- eCos
- InTime
- Proconos OS
- Real Time Java
- RMOS
- RT Kernel
- RT Linux
- RTX C Quadros
- QNX
- VxWin + CeWin
- VxWorks
- Windows CE
- Windows XP/XPE with Codesys-SP
- Windows XP/XPE with TwinCAT RT-Extension
- XENOMAI Linux

open source code available



* As of Feb 2008

EtherCAT is well proven

EtherCAT is:

- faster ✓
- Industrial Ethernet ✓
- more flexible to wire ✓
- easier to configure ✓
- lower cost ✓
- easier to implement ✓
- well proven
- open
- safety
- redundancy
- versatile

- in series production since 2003
- more nodes shipped than PROFINET, Powerlink V 2 and SERCOS III altogether...



EtherCAT Architecture + Device Profiles

EtherCAT is:

- faster ✓
- Industrial Ethernet ✓
- more flexible to wire ✓
- easier to configure ✓
- lower cost ✓
- easier to implement ✓
- well proven ✓
- open
- safety
- redundancy
- versatile

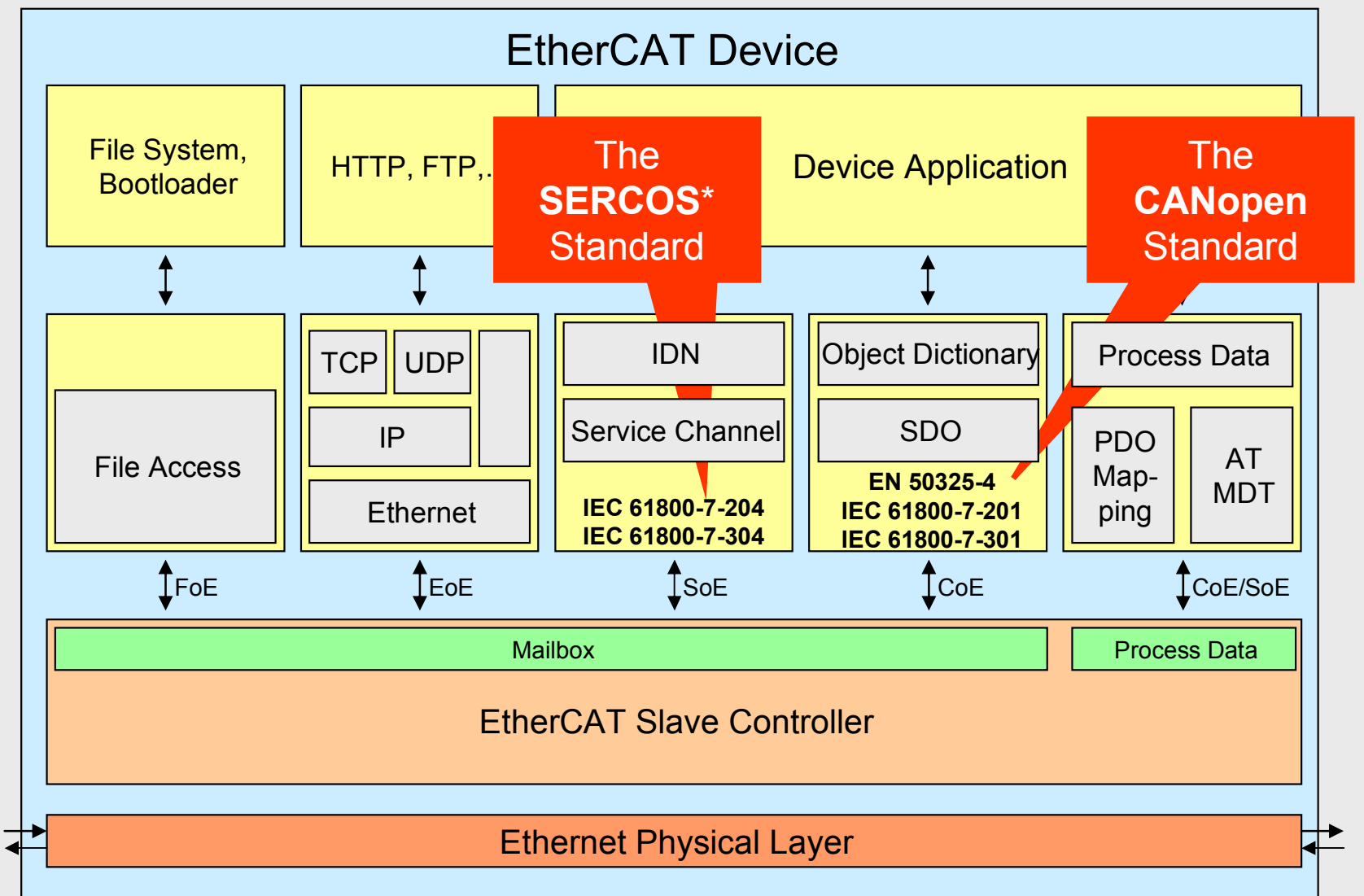

*SERCOS interface™ is a trademark by SI e.V.

Typical EtherCAT Device Architecture

EtherCAT is:

- faster ✓
- Industrial Ethernet ✓
- more flexible to wire ✓
- easier to configure ✓
- lower cost ✓
- easier to implement ✓
- well proven ✓
- open
- safety
- redundancy
- versatile

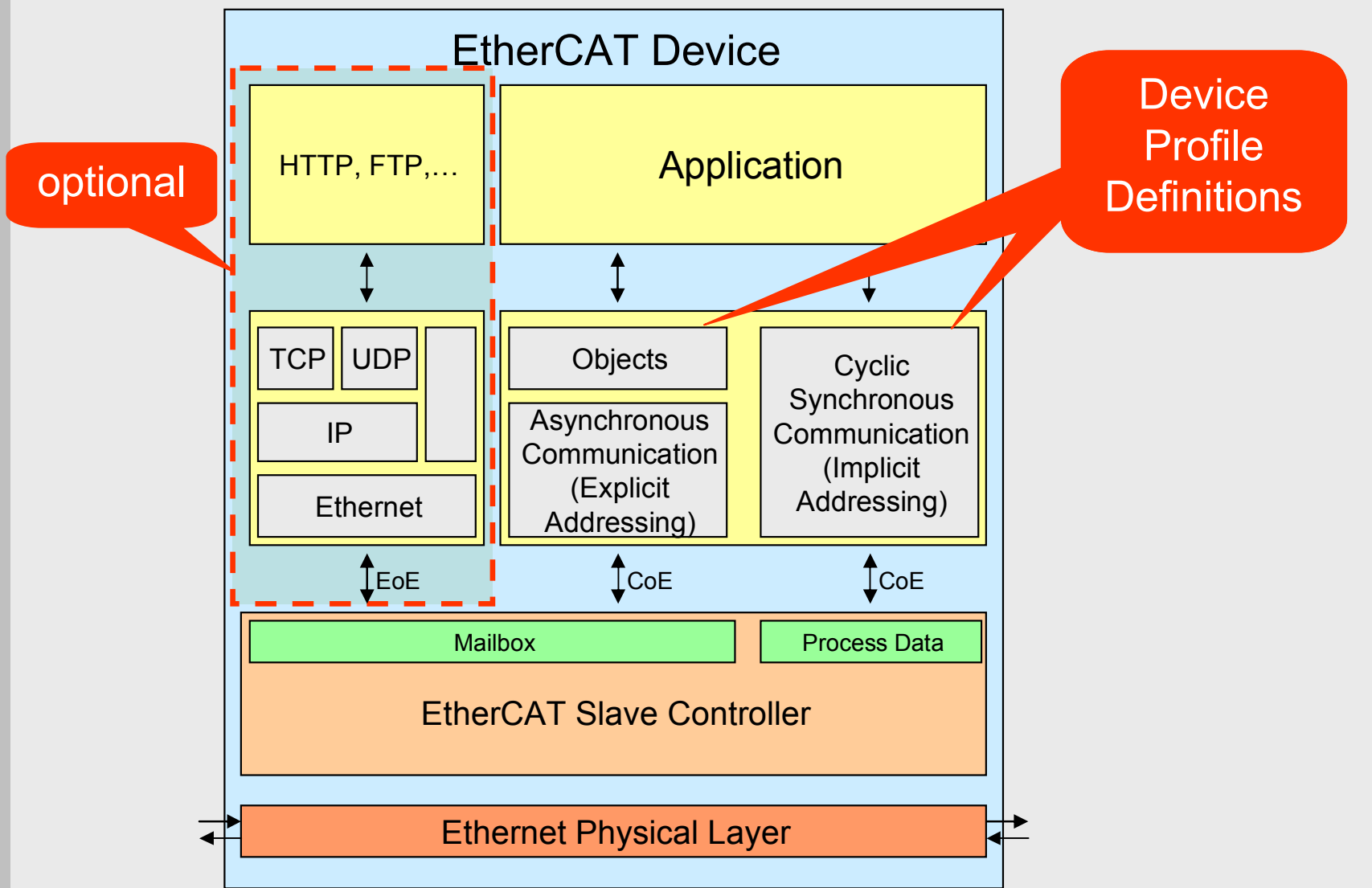

- EtherCAT is:
- faster ✓
 - Industrial Ethernet ✓
 - more flexible to wire ✓
 - easier to configure ✓
 - lower cost ✓
 - easier to implement ✓
 - well proven ✓
 - open
 - safety
 - redundancy
 - versatile

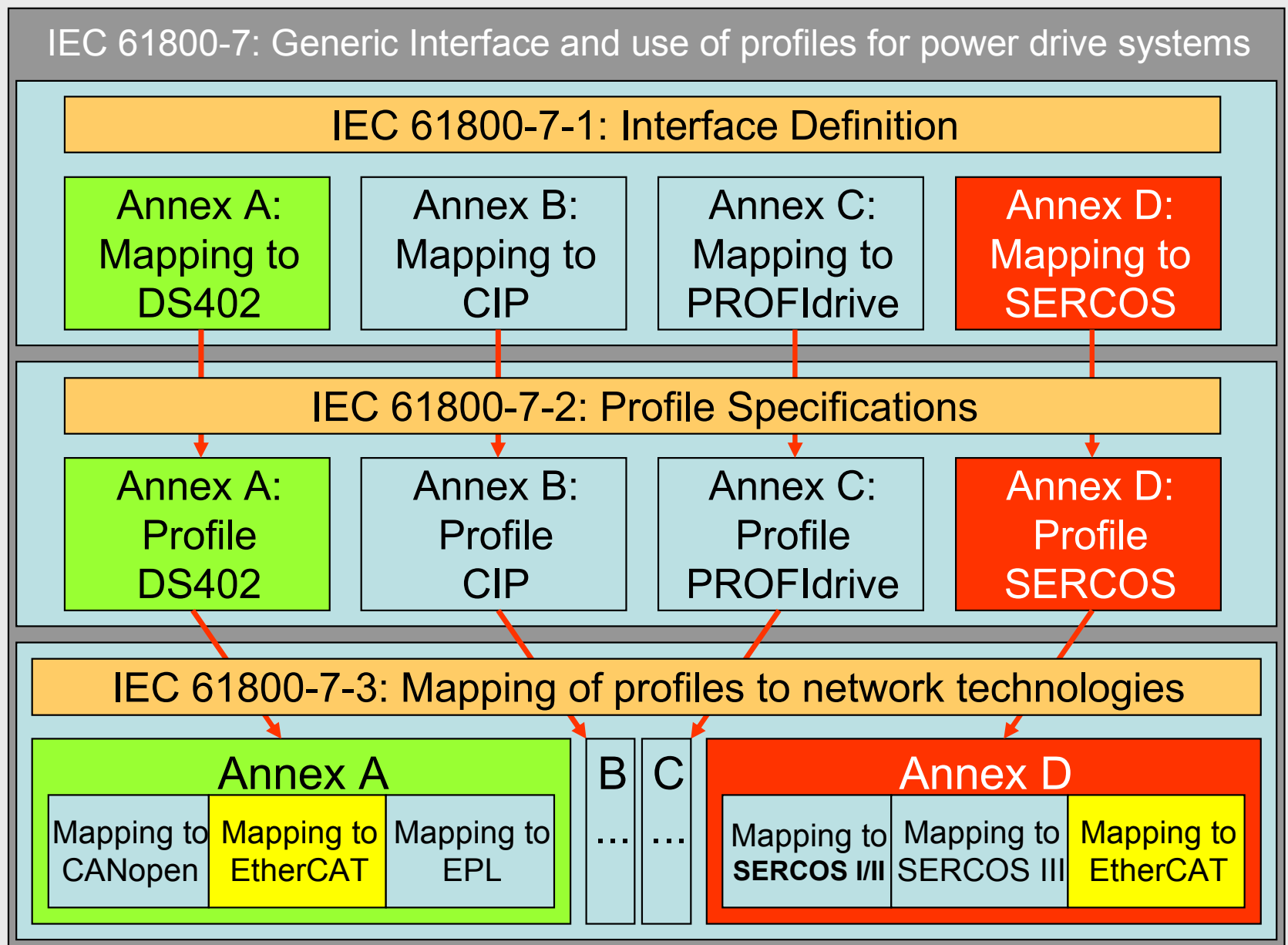

EtherCAT is an open technology



- Foundation: November 2003
- Tasks: Support, Advancement and Promotion of EtherCAT
- The worlds largest organization dedicated to Industrial Ethernet
- more than 725* member companies from 41 countries in 6 continents:
 - Device Manufacturers
 - End Users
 - Technology-Providers
- Membership is open to everybody

EtherCAT is:

- faster ✓
- Industrial Ethernet ✓
- more flexible to wire ✓
- easier to configure ✓
- lower cost ✓
- easier to implement ✓
- well proven ✓
- open
- safety
- redundancy
- versatile

•as of April 2008

EtherCAT Technology Group Membership Development

EtherCAT is:

- faster ✓
- Industrial Ethernet ✓
- more flexible to wire ✓
- easier to configure ✓
- lower cost ✓
- easier to implement ✓
- well proven ✓
- open
- safety
- redundancy
- versatile

As of April 15, 2008: **733** Members

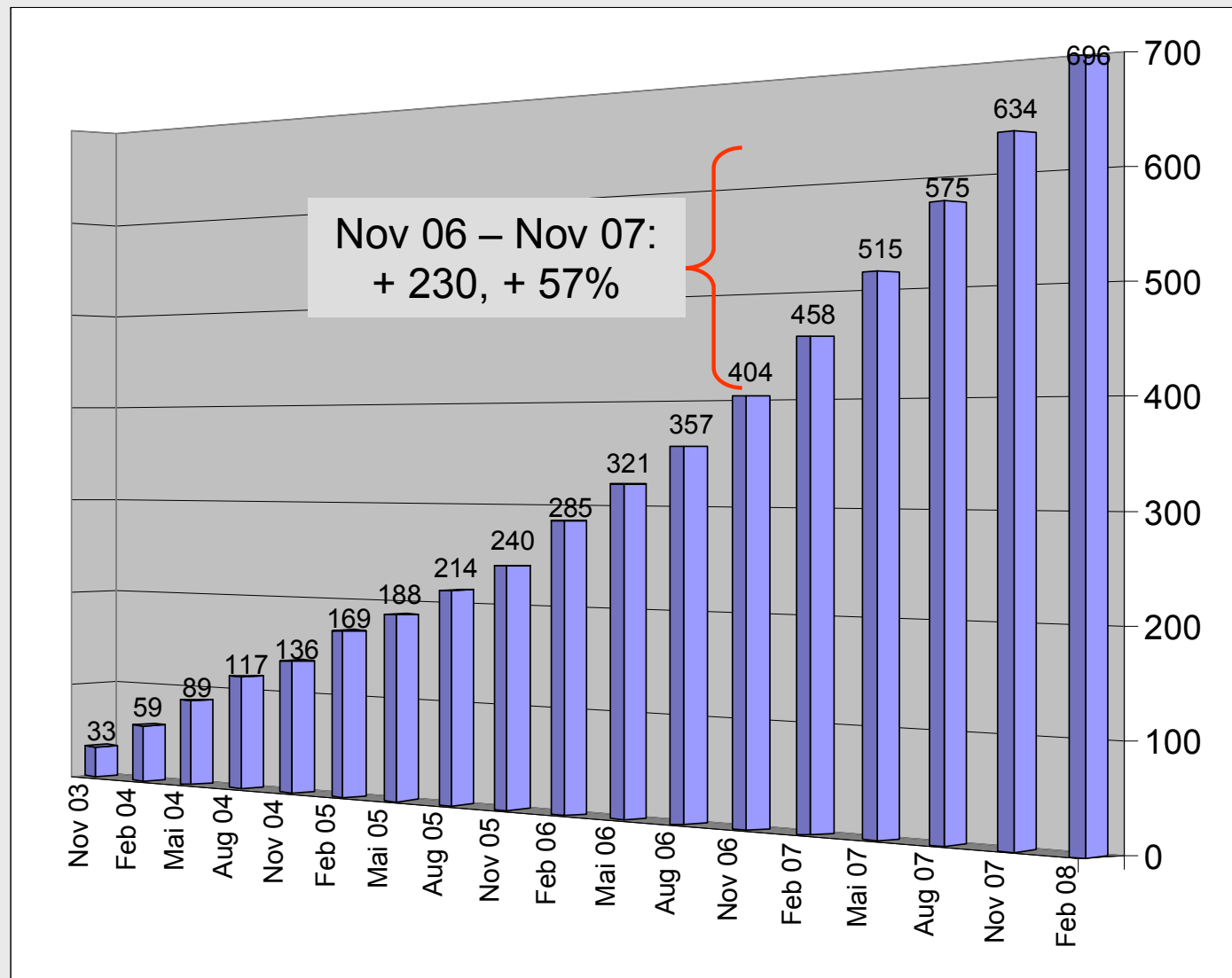

Members from 41 Countries, 6 Continents

EtherCAT is:

- faster ✓
- Industrial Ethernet ✓
- more flexible to wire ✓
- easier to configure ✓
- lower cost ✓
- easier to implement ✓
- well proven ✓
- open
- safety
- redundancy
- versatile



Australia



Austria



Belarus



Belgium



Brazil



Canada



China



Croatia



Czech Rep



Denmark



Finland



France



Germany



Greece



Hungary



India



Israel



Italy



Japan



Korea



Liechtenstein



Netherlands



Norway



Poland



Portugal



Romania



Russia



Serbia



Singapore



Slovakia



Slovenia



South Africa



Spain



Sweden



Switzerland



Taiwan



Thailand



Turkey



Ukraine



United Kingdom



USA

EtherCAT Technology Group Members (as of March 2008)

EtherCAT is:

- faster ✓
- Industrial Ethernet ✓
- more flexible to wire ✓
- easier to configure ✓
- lower cost ✓
- easier to implement ✓
- well proven ✓
- open
- safety
- redundancy
- versatile



ETG: Active Members

EtherCAT is:

- faster ✓
- Industrial Ethernet ✓
- more flexible to wire ✓
- easier to configure ✓
- lower cost ✓
- easier to implement ✓
- well proven ✓
- open
- safety
- redundancy
- versatile

- Much more important than membership figures: how many are active, how many implement the technology?
- April 2008: More than 550 Implementation Kits sold to ETG Members (28% Master, 72% Slaves), plus there are Open Core masters!
- SPS/IPC/Drives 2008: 54 Vendors with over 150 different EtherCAT Devices at ETG booth
 - among those 25 drives and 20 different Masters in function, using 10 different operating systems



EtherCAT is an open technology

EtherCAT is:

- faster ✓
- Industrial Ethernet ✓
- more flexible to wire ✓
- easier to configure ✓
- lower cost ✓
- easier to implement ✓
- well proven ✓
- open
- safety
- redundancy
- versatile

- Protocol is disclosed completely:
- EtherCAT is IEC and ISO Standard (IEC 61158, IEC 61784-2, ISO 15745-4)



Commission Electrotechnique Internationale
International Electrotechnical Commission
Международная Электротехническая Комиссия



- Slave Controller from several sources available
- Slave Controller provides interoperability
- Master Stacks for various RTOS available

Safety over EtherCAT: Features

EtherCAT is:

- faster ✓
- Industrial Ethernet ✓
- more flexible to wire ✓
- easier to configure ✓
- lower cost ✓
- easier to implement ✓
- well proven ✓
- open ✓
- safety
- redundancy
- versatile

- Fully integrated solution:
 - safe and standard communication in one channel
- Reduction of fieldbuses and interfaces
- Central configuration, diagnosis and maintenance for safe and ,unsafe‘ I/O in one Tool
- Safety application makes full use of EtherCAT advantages:
 - ✓ Short reaction times
 - ✓ Almost unlimited no. of nodes
 - ✓ Large network extensions
 - ✓ Cable redundancy options
 - ✓ High Flexibility with Hot Connect

Safety over EtherCAT: Technology Approach

EtherCAT is:

- faster ✓
- Industrial Ethernet ✓
- more flexible to wire ✓
- easier to configure ✓
- lower cost ✓
- easier to implement ✓
- well proven ✓
- open ✓
- safety
- redundancy
- versatile

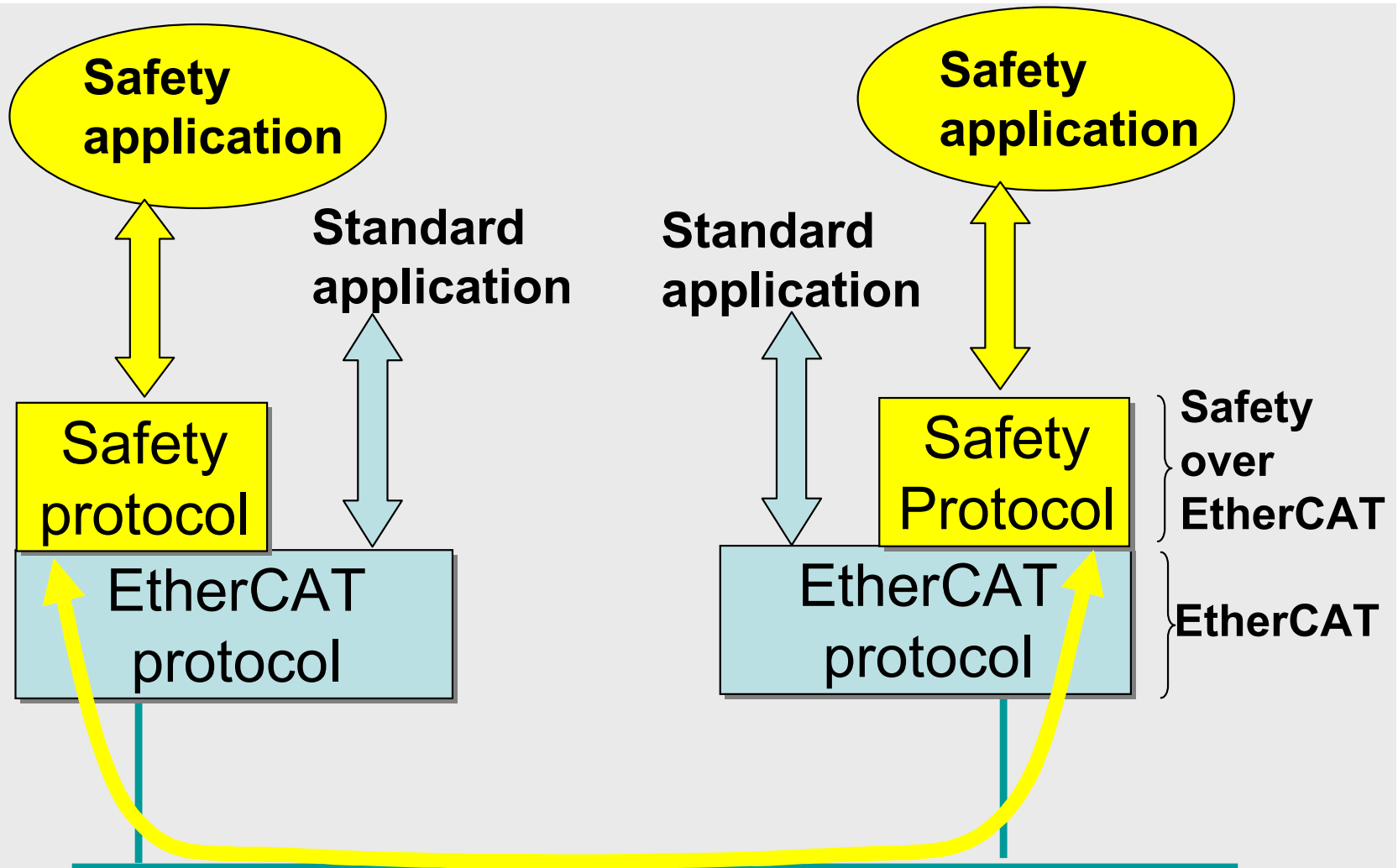

EtherCAT acts as a real 'black channel'

Safety over EtherCAT: Implementations

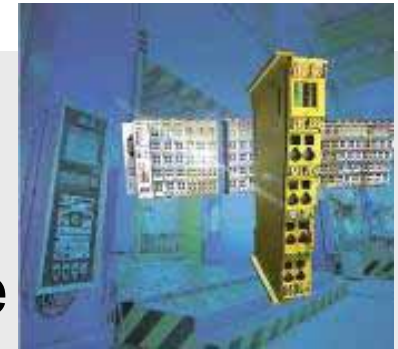

- Decentralized Safety Logic
- Works with Standard PLC
- PLC simply organizes data exchange

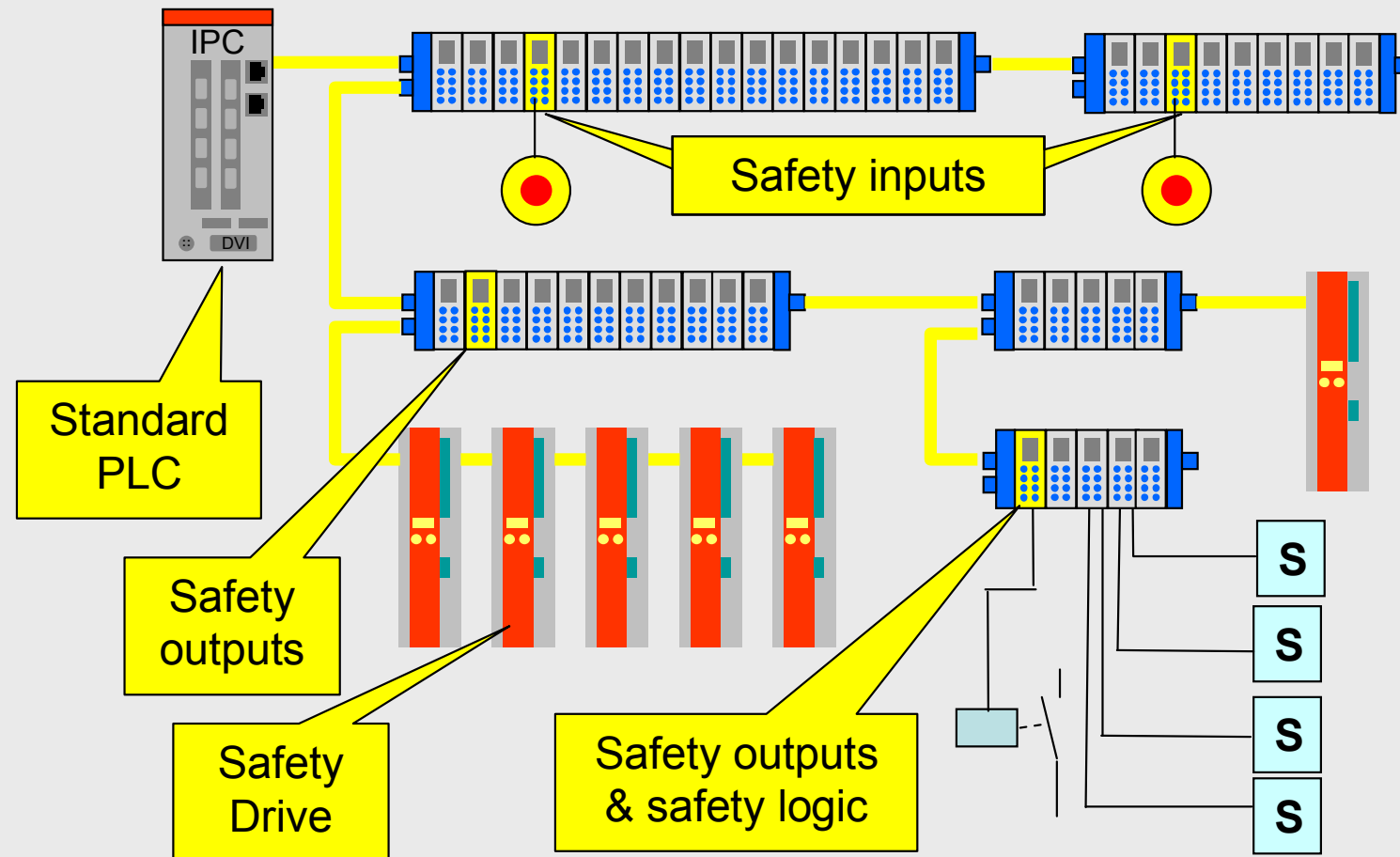

EtherCAT is:

- faster ✓
- Industrial Ethernet ✓
- more flexible to wire ✓
- easier to configure ✓
- lower cost ✓
- easier to implement ✓
- well proven ✓
- open ✓
- safety
- redundancy
- versatile

Without Redundancy: Normal Operation

EtherCAT is:

- faster ✓
- Industrial Ethernet ✓
- more flexible to wire ✓
- easier to configure ✓
- lower cost ✓
- easier to implement ✓
- well proven ✓
- open ✓
- safety ✓
- redundancy
- versatile

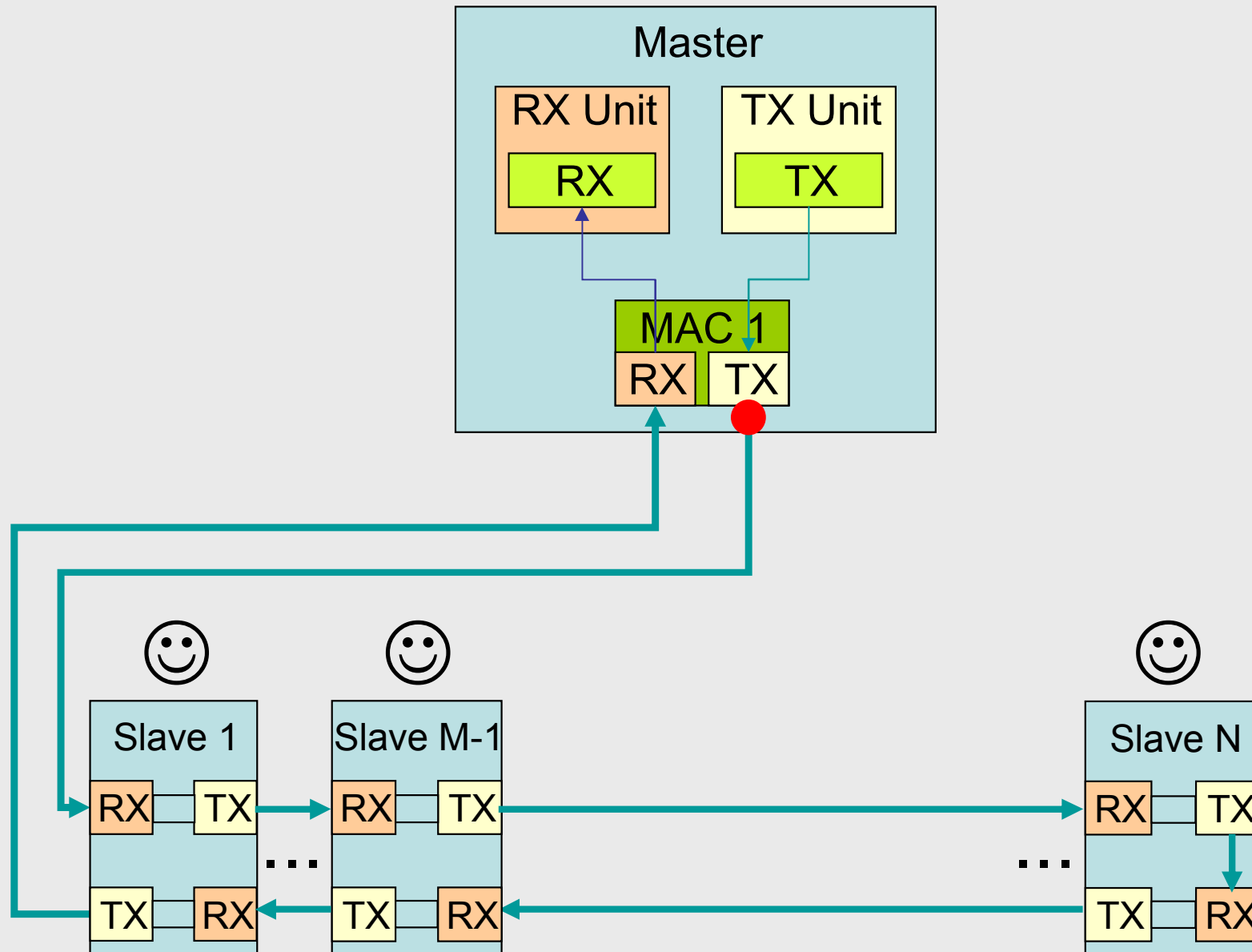

Without Redundancy: Cable Failure

EtherCAT is:

- faster ✓
- Industrial Ethernet ✓
- more flexible to wire ✓
- easier to configure ✓
- lower cost ✓
- easier to implement ✓
- well proven ✓
- open ✓
- safety ✓
- redundancy
- versatile

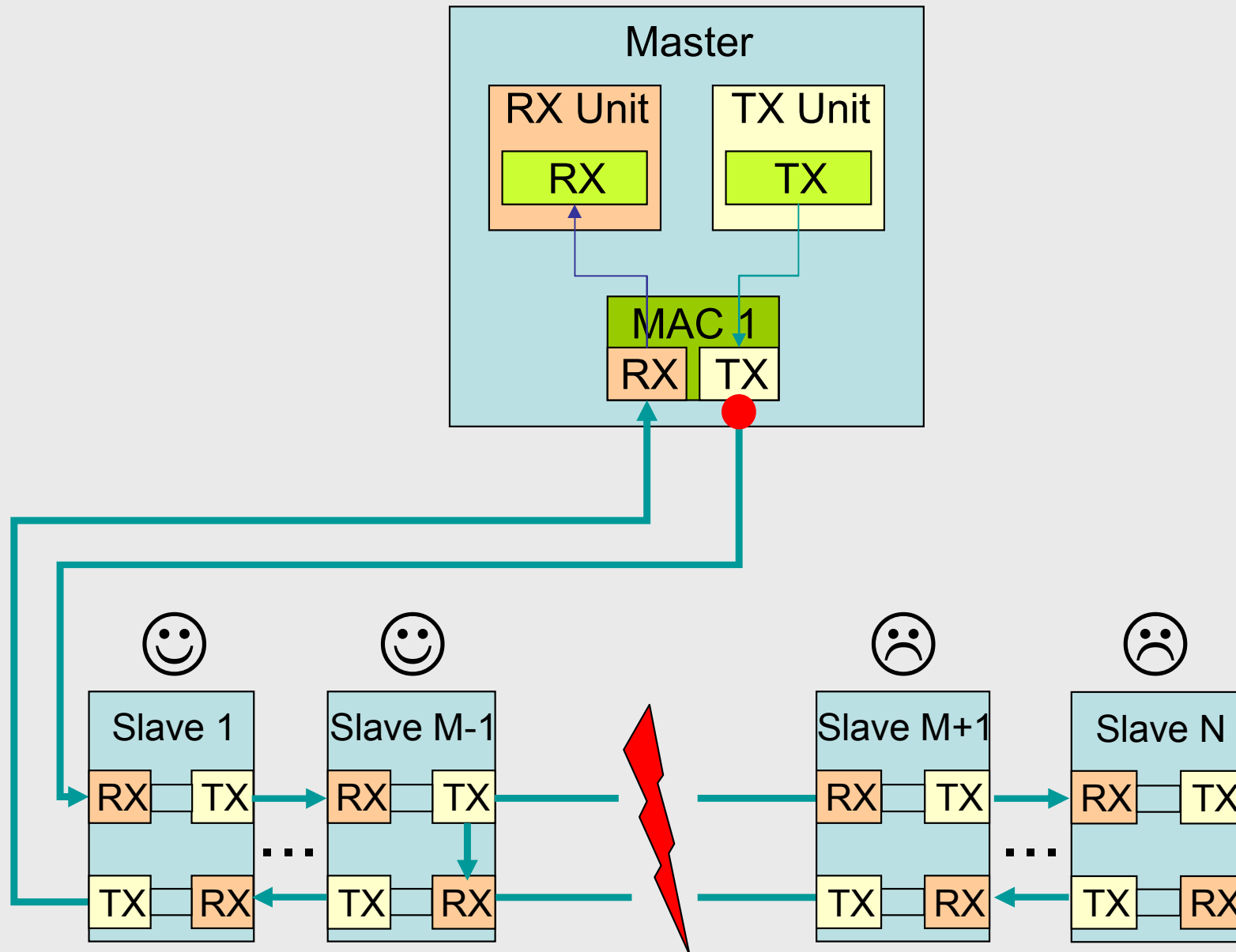

Without Redundancy: Node Failure

EtherCAT is:

- faster ✓
- Industrial Ethernet ✓
- more flexible to wire ✓
- easier to configure ✓
- lower cost ✓
- easier to implement ✓
- well proven ✓
- open ✓
- safety ✓
- **redundancy**
- versatile

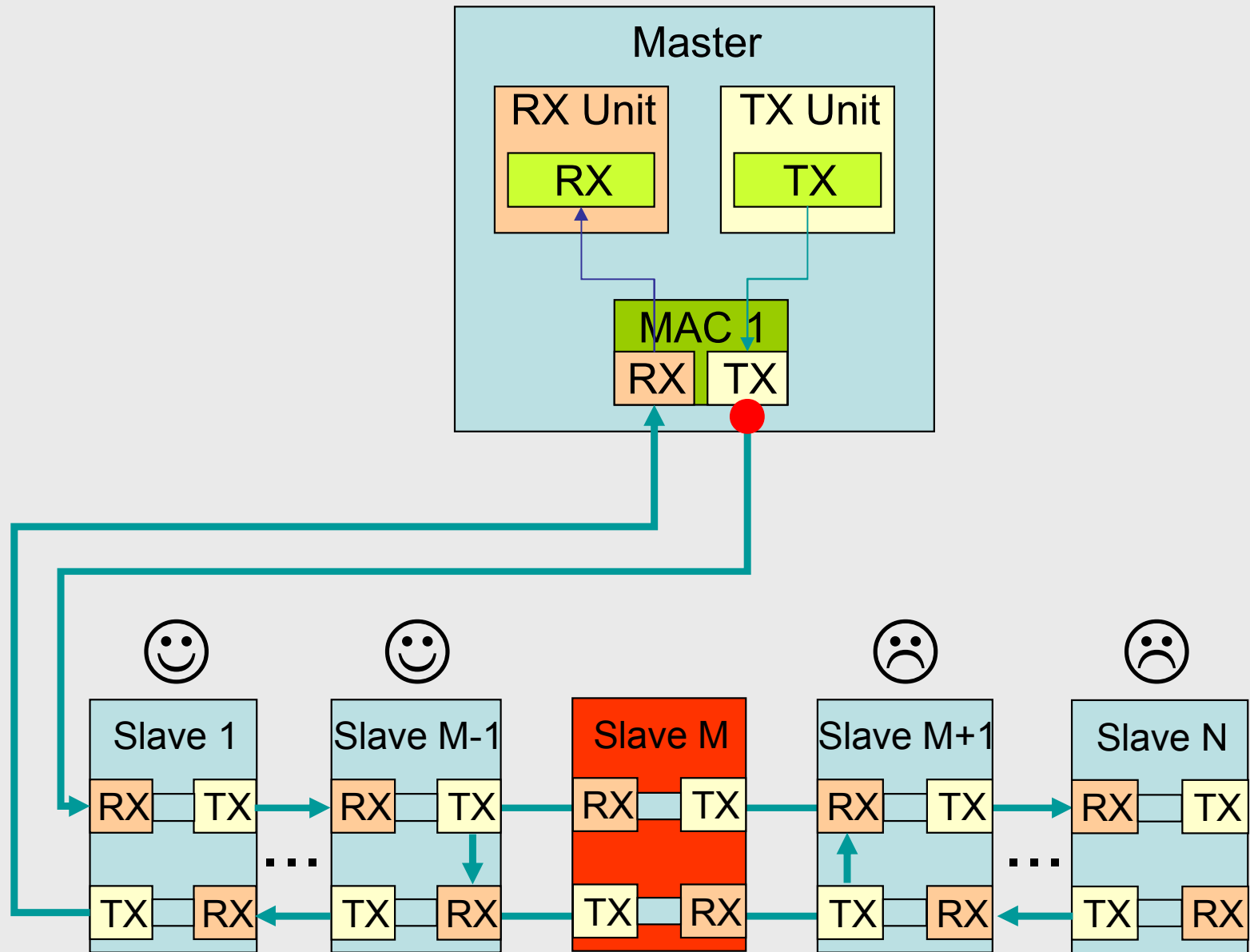

With Redundancy: Normal Operation

EtherCAT is:

- faster ✓
- Industrial Ethernet ✓
- more flexible to wire ✓
- easier to configure ✓
- lower cost ✓
- easier to implement ✓
- well proven ✓
- open ✓
- safety ✓
- redundancy
- versatile

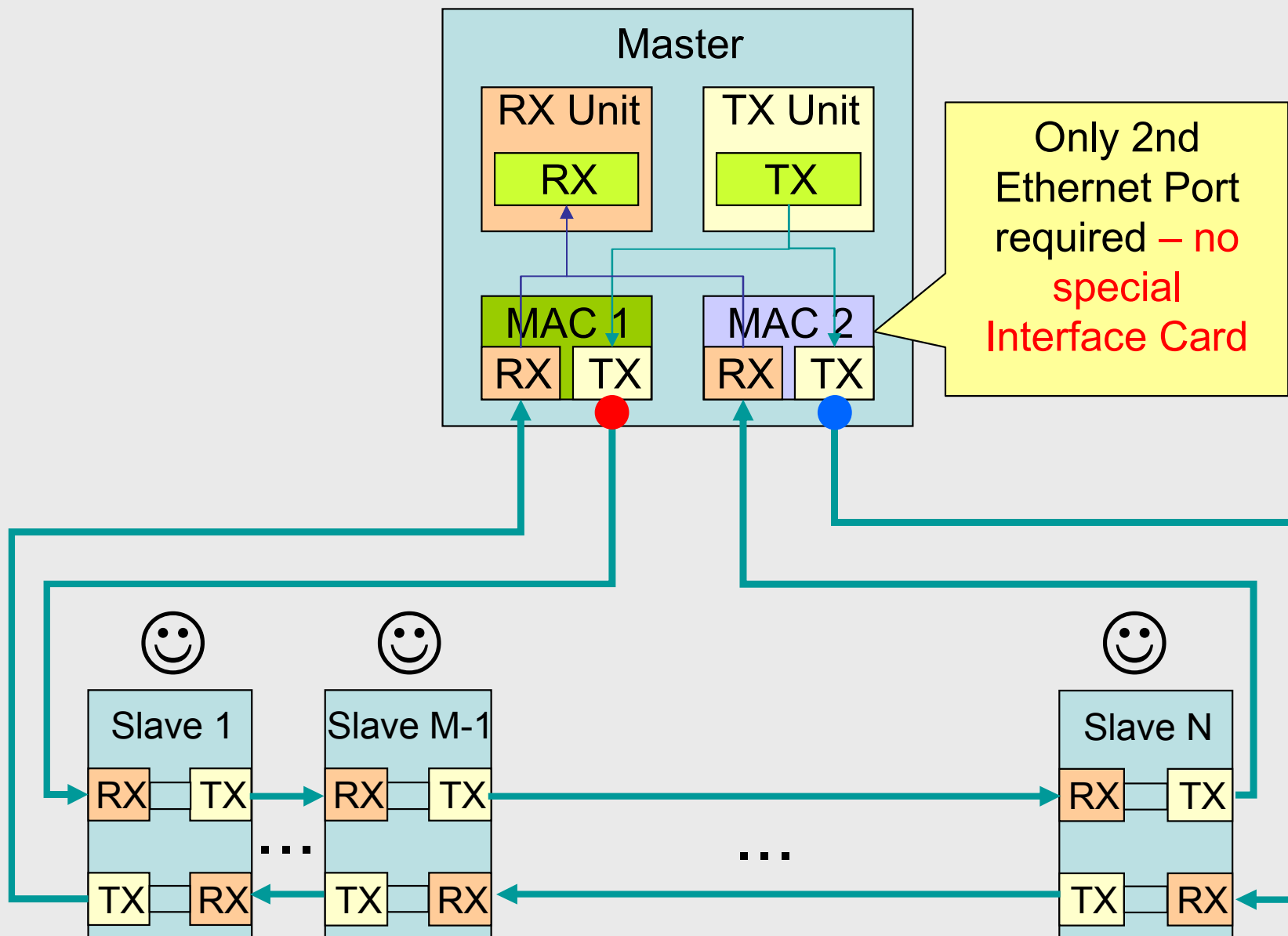

With Redundancy: Cable Failure

EtherCAT is:

- faster ✓
- Industrial Ethernet ✓
- more flexible to wire ✓
- easier to configure ✓
- lower cost ✓
- easier to implement ✓
- well proven ✓
- open ✓
- safety ✓
- redundancy ✓
- versatile ✓

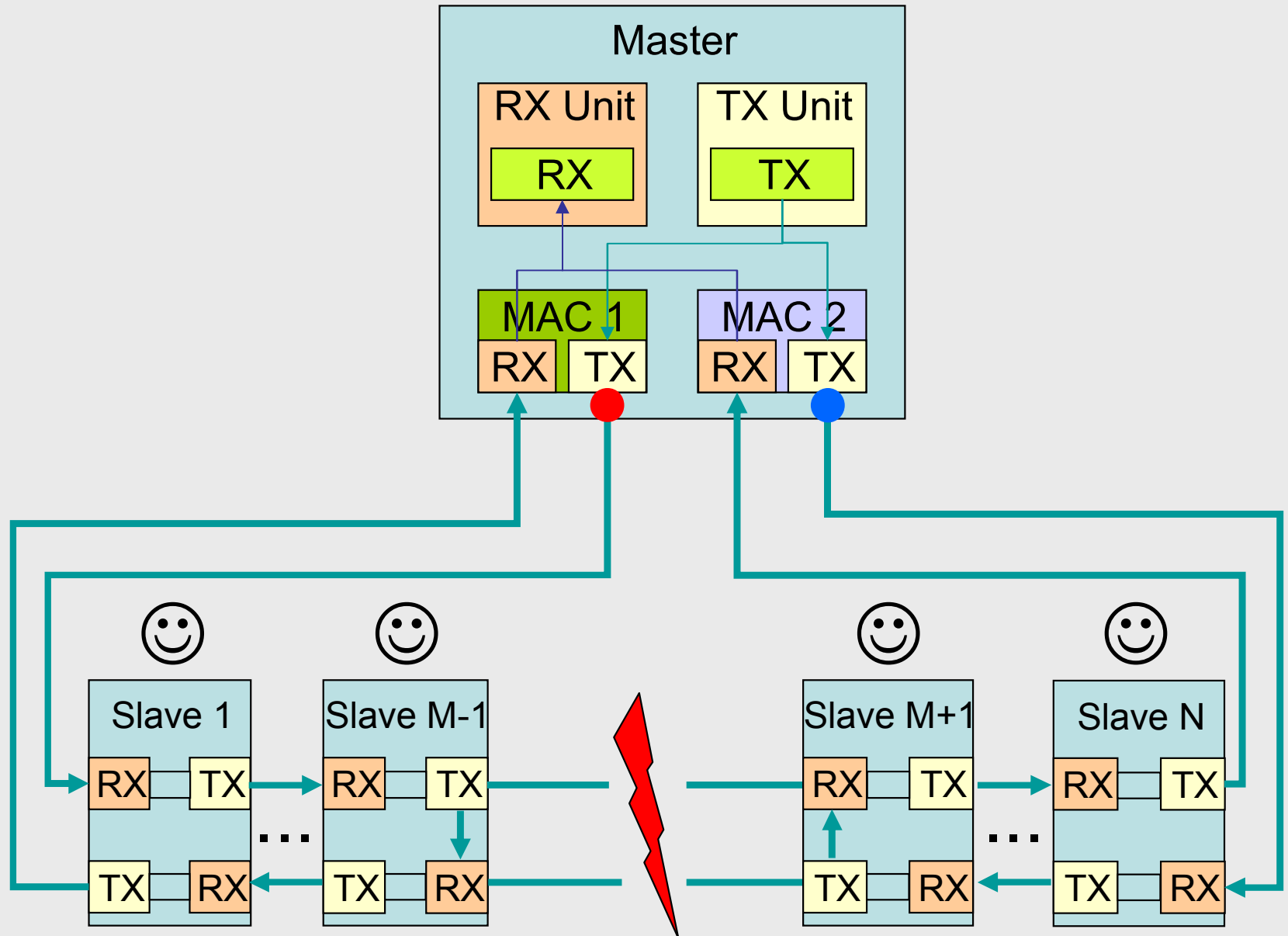

With Redundancy: Node Failure

EtherCAT is:

- faster ✓
- Industrial Ethernet ✓
- more flexible to wire ✓
- easier to configure ✓
- lower cost ✓
- easier to implement ✓
- well proven ✓
- open ✓
- safety ✓
- redundancy ✓
- versatile ✓

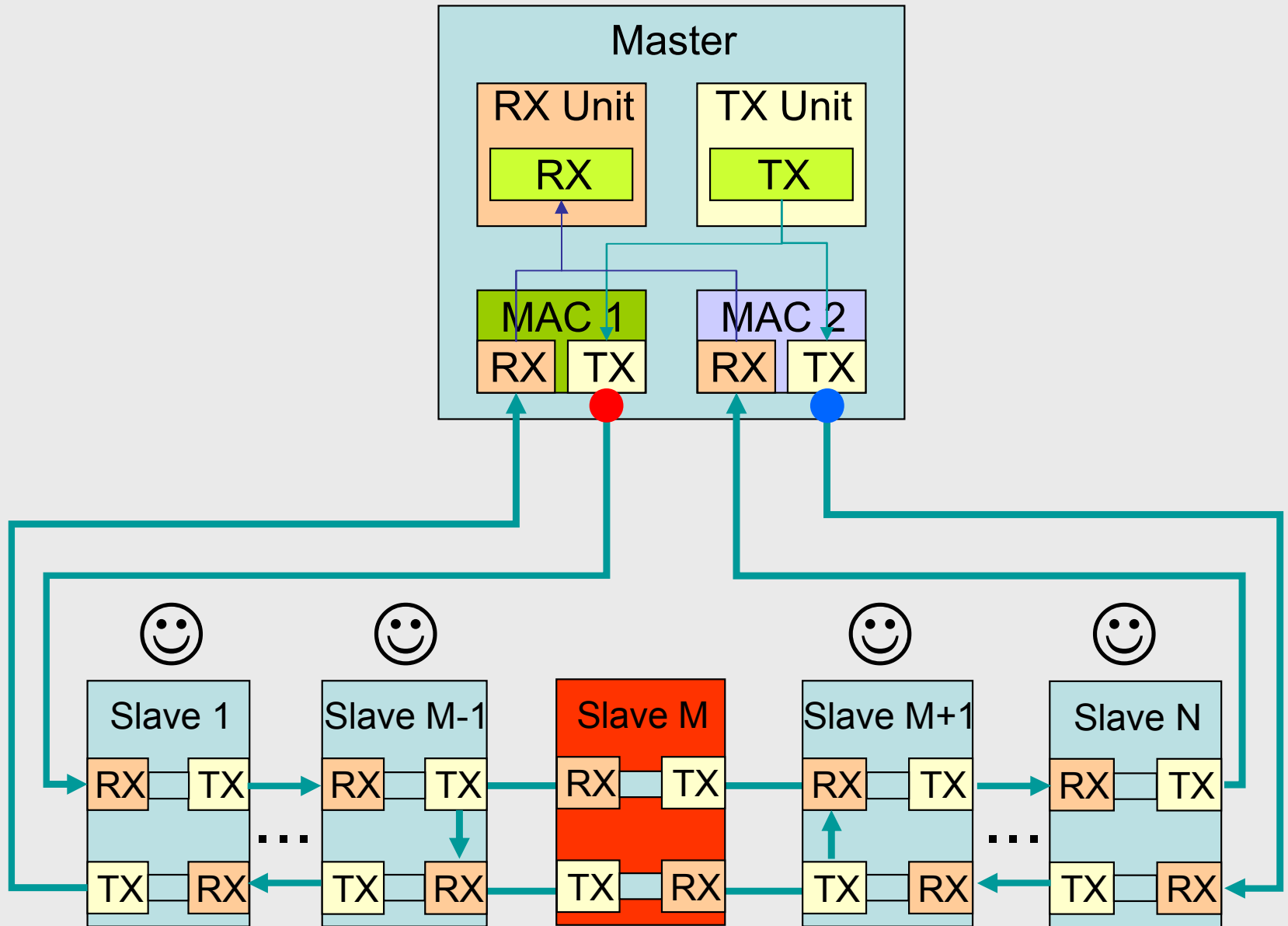

EtherCAT is:

- faster ✓
- Industrial Ethernet ✓
- more flexible to wire ✓
- easier to configure ✓
- lower cost ✓
- easier to implement ✓
- well proven ✓
- open ✓
- safety ✓
- redundancy
- versatile

- Master redundancy with Hot-Stand-By
- Cabling redundancy
- Hot Swap of devices
- Hot-Connect of network segments

EtherCAT Application Fields, or: Why do Companies chose EtherCAT?

EtherCAT is:

- faster ✓
- Industrial Ethernet ✓
- more flexible to wire ✓
- easier to configure ✓
- lower cost ✓
- easier to implement ✓
- well proven ✓
- open ✓
- safety ✓
- redundancy ✓
- versatile ✓

High Performance

EtherCAT is the fastest Industrial Ethernet Technology

Flexible Topology

Benefit not only for widely distributed applications

Ease of Use

Easy configuration and maintenance

Low Cost

Inexpensive implementation + Infrastructure

Functional Safety

Safety communication integrated

Decisive Factors: Performance

EtherCAT is the fastest Industrial Ethernet Technology

*The need for speed:
Everything that is high end motion control*

For example

- **Robotics**
- **Hydraulic / Electric Presses**
- **Machine Tool Applications**
- **CNC functionality**
- **Printing**
- **Woodworking machines**
- **Packaging Machines**
- **Injection Molding**
- **Any measurement application**
- **Any closed loop control**



EtherCAT is:

- faster ✓
- Industrial Ethernet ✓
- more flexible to wire ✓
- easier to configure ✓
- lower cost ✓
- easier to implement ✓
- well proven ✓
- open ✓
- safety ✓
- redundancy ✓
- versatile ✓

Decisive Factors: Performance

EtherCAT is:

- faster ✓
- Industrial Ethernet ✓
- more flexible to wire ✓
- easier to configure ✓
- lower cost ✓
- easier to implement ✓
- well proven ✓
- open ✓
- safety ✓
- redundancy ✓
- versatile ✓

Example: Hydraulic Presses

Dieffenbacher: Presses and more



Decisive Factors: Performance



Example: Test Bed Application BMW AG: Engine Test Bed



Photos: BMW AG

EtherCAT is:

- faster ✓
- Industrial Ethernet ✓
- more flexible to wire ✓
- easier to configure ✓
- lower cost ✓
- easier to implement ✓
- well proven ✓
- open ✓
- safety ✓
- redundancy ✓
- versatile ✓

Decisive Factors: Performance

Example: Printing Systems

EtherCAT is:

- faster ✓
- Industrial Ethernet ✓
- more flexible to wire ✓
- easier to configure ✓
- lower cost ✓
- easier to implement ✓
- well proven ✓
- open ✓
- safety ✓
- redundancy ✓
- versatile



Decisive Factors: Performance

EtherCAT is:

- faster ✓
- Industrial Ethernet ✓
- more flexible to wire ✓
- easier to configure ✓
- lower cost ✓
- easier to implement ✓
- well proven ✓
- open ✓
- safety ✓
- redundancy ✓
- versatile

Example: Machines with CNC functionality

Laserplus Oy: Welding Transfer line for steel sandwich-plates



Decisive Factors: Performance

EtherCAT is:

- faster ✓
- Industrial Ethernet ✓
- more flexible to wire ✓
- easier to configure ✓
- lower cost ✓
- easier to implement ✓
- well proven ✓
- open ✓
- safety ✓
- redundancy ✓
- versatile

Example: Woodworking Machines

Nobilis Werke: Kitchen Production



Decisive Factors: Performance

EtherCAT is:

- faster ✓
- Industrial Ethernet ✓
- more flexible to wire ✓
- easier to configure ✓
- lower cost ✓
- easier to implement ✓
- well proven ✓
- open ✓
- safety ✓
- redundancy ✓
- versatile

Example: Packaging Machines

Radiator Specialty, (NC), USA: Filling and Packaging Line



Decisive Factors: Performance

Example: Postpress Processing Machine

Ferag, Switzerland:

Flexible, modular strapping without bundle turning (SmartStrap)



EtherCAT is:

- faster ✓
- Industrial Ethernet ✓
- more flexible to wire ✓
- easier to configure ✓
- lower cost ✓
- easier to implement ✓
- well proven ✓
- open ✓
- safety ✓
- redundancy ✓
- versatile

Decisive Factors: Performance

EtherCAT is:

- faster ✓
- Industrial Ethernet ✓
- more flexible to wire ✓
- easier to configure ✓
- lower cost ✓
- easier to implement ✓
- well proven ✓
- open ✓
- safety ✓
- redundancy ✓
- versatile

Example: Injection Molding

Husky (Canada): HyPAC



Decisive Factors: Performance

Example: Measurement Application: Airbus Testrack for High-Lift-System

Ingenieurgesellschaft IgH: High Lift Slat Flap Testrig (HLSTR)

EtherCAT is:

- faster ✓
- Industrial Ethernet ✓
- more flexible to wire ✓
- easier to configure ✓
- lower cost ✓
- easier to implement ✓
- well proven ✓
- open ✓
- safety ✓
- redundancy ✓
- versatile



Decisive Factors: **Topology**

Example: **Bridge absorption system**

Dubrovnik (Croatia): Absorption of vibrations



EtherCAT is:

- faster ✓
- Industrial Ethernet ✓
- more flexible to wire ✓
- easier to configure ✓
- lower cost ✓
- easier to implement ✓
- well proven ✓
- open ✓
- safety ✓
- redundancy ✓
- versatile

Decisive Factors: **Topology**

EtherCAT is:

- faster ✓
- Industrial Ethernet ✓
- more flexible to wire ✓
- easier to configure ✓
- lower cost ✓
- easier to implement ✓
- well proven ✓
- open ✓
- safety ✓
- redundancy ✓
- versatile

Example: **Snow Blower Control**

Berchtold, Austria:
Systems of up to 1000 snow makers



Decisive Factors: **Ease of Use**

EtherCAT is:

- faster ✓
- Industrial Ethernet ✓
- more flexible to wire ✓
- easier to configure ✓
- lower cost ✓
- easier to implement ✓
- well proven ✓
- open ✓
- safety ✓
- redundancy ✓
- versatile ✓

EtherCAT is easier to use:

- **No Hassle with Address Switches**
- **No Bandwidth or performance issues, no network tuning**
- **Simple Configuration**
- **Meaningful Diagnosis Information**

Decisive Factors: **Ease of Use**

EtherCAT is:

- faster ✓
- Industrial Ethernet ✓
- more flexible to wire ✓
- easier to configure ✓
- lower cost ✓
- easier to implement ✓
- well proven ✓
- open ✓
- safety ✓
- redundancy ✓
- versatile

Example: Mat Welding Machine
Progress, Italy

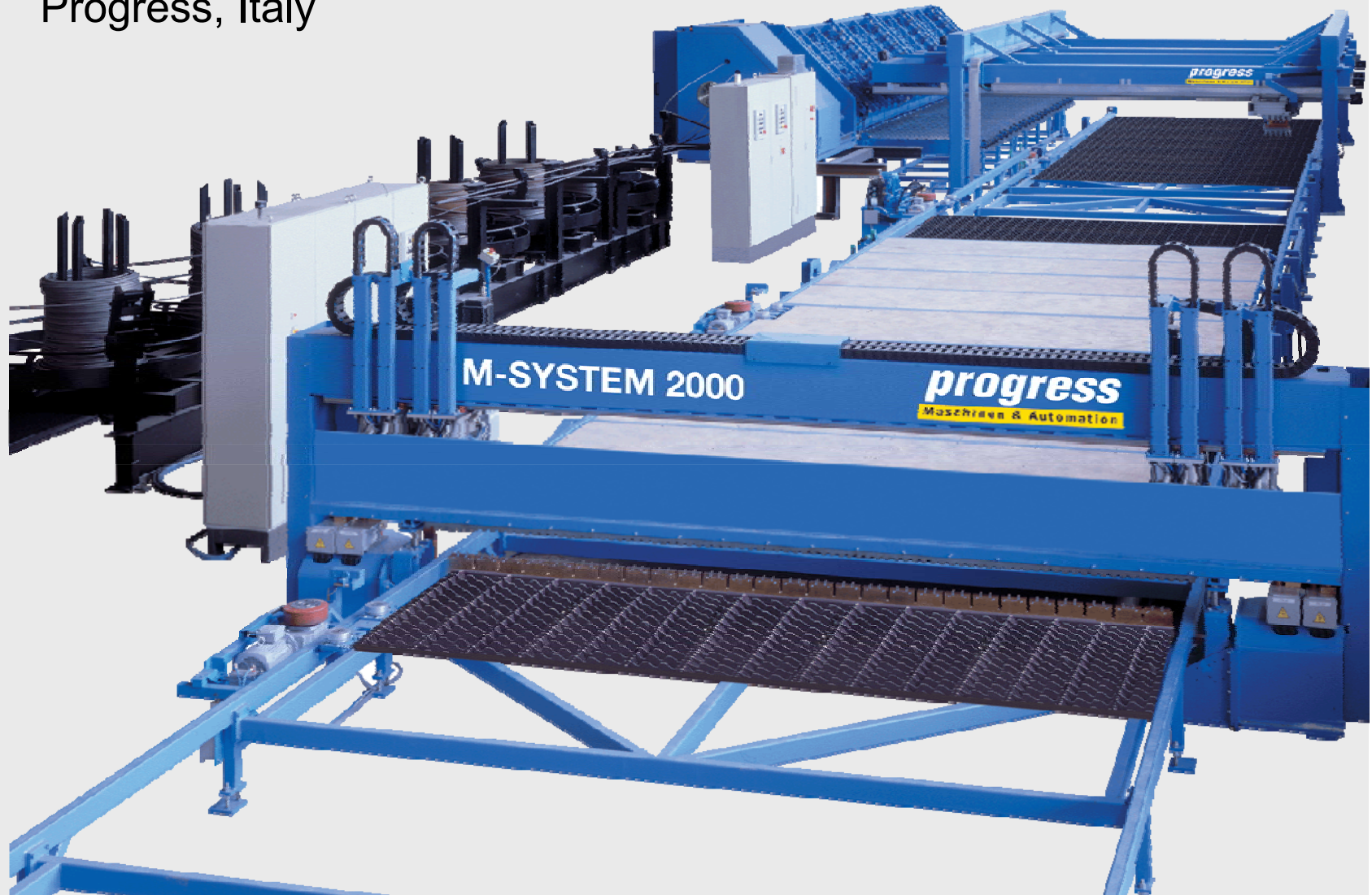

Decisive Factors: **Ease of Use**

EtherCAT is:

- faster ✓
- Industrial Ethernet ✓
- more flexible to wire ✓
- easier to configure ✓
- lower cost ✓
- easier to implement ✓
- well planned ✓
- open ✓
- safety ✓
- redundancy ✓
- versatile

Example: Coil Wire Processing Machine
Progress, Italy



Decisive Factors: Costs

EtherCAT is:

- faster ✓
- Industrial Ethernet ✓
- more flexible to wire ✓
- easier to configure ✓
- lower cost ✓
- easier to implement ✓
- well proven ✓
- open ✓
- safety ✓
- redundancy ✓
- versatile

Example: Edge Banding Machine IMA: Novimat Concept



Decisive Factors: **Functional Safety**

EtherCAT is:

- faster ✓
- Industrial Ethernet ✓
- more flexible to wire ✓
- easier to configure ✓
- lower cost ✓
- easier to implement ✓
- well proven ✓
- open ✓
- safety ✓
- redundancy ✓
- versatile ✓

Example: Tire Testing System Seichter, Germany



www.ethercat.org

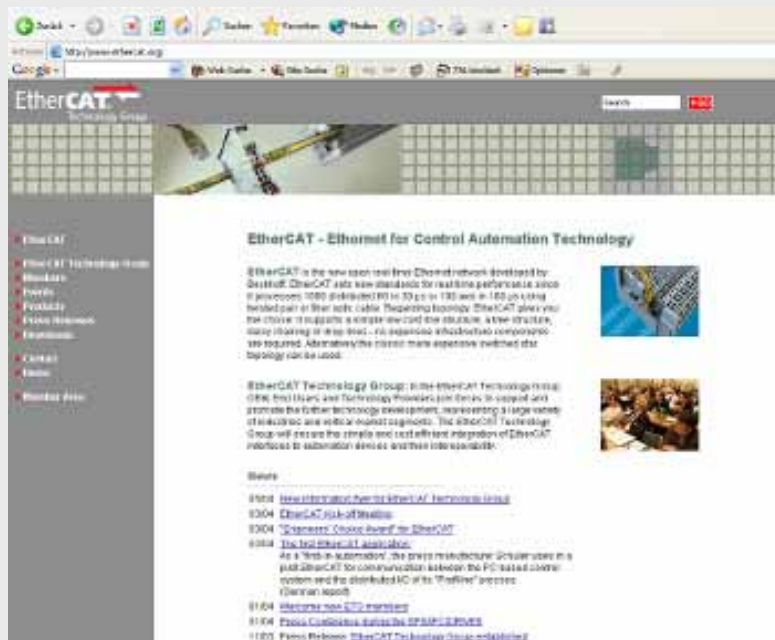

Martin Rostan
 EtherCAT Technology Group
 Ostendstr. 196
 90482 Nuremberg, Germany
 Phone. +49 911 54056-20, Fax -29
 m.rostan@ethercat.org

EtherCAT is:

- faster ✓
- Industrial Ethernet ✓
- more flexible to wire ✓
- easier to configure ✓
- lower cost ✓
- easier to implement ✓
- well proven ✓
- open ✓
- safety ✓
- redundancy ✓
- versatile ✓